

IWAKI

MP
Series

Metallic Centrifugal Magnet Drive Pumps



**Extensive Hydraulic Performance, Seal-less,
Corrosion Resistant , Leak Free**



MP

Small / Medium Sized Standard Centrifugal Pumps

- » Compact, metallic centrifugal magnet drive pumps
- » Excellent heat and pressure resistance
- » Cover a wide range of motor capacities, up to 15 kW
- » Pump materials offer excellent corrosion resistance
- » This model can transfer liquid below freezing
- » Stainless Steel is standard. Other materials available on request
- » Magnet drive is supported by the exclusive SiC-D bearing
- » High efficiency and leak free design
- » Easy to disassemble and reassemble
- » Industry-leading support by Iwaki Europe

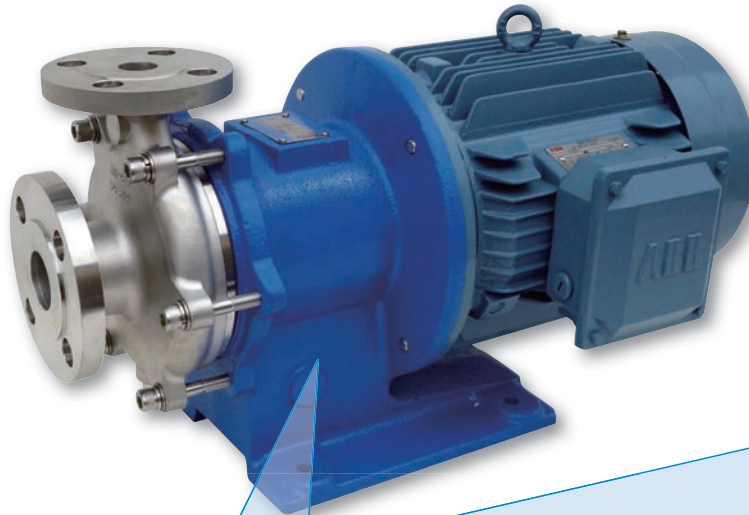

TYPE MP
Motor output :
0,75 kW to 15 kW



[Highly reliable block-building structure]

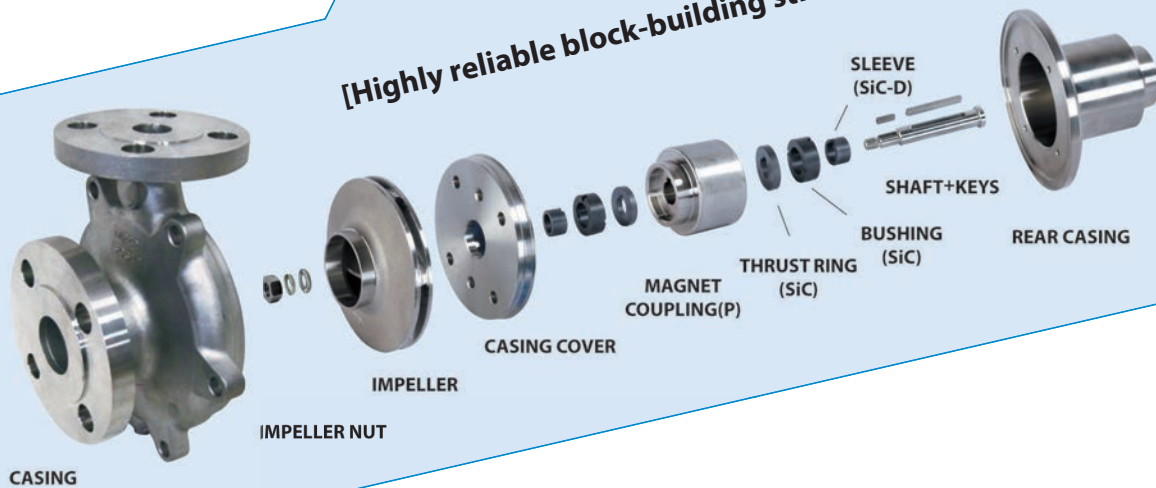

PB Assembly

PB Assembly is a completely assembled wet end rotating element including impeller, casing cover, bearings, inner magnet coupling(P), shaft and rear casing.

PB assembly enable you to replace the wet end of the pump easily and quickly.

For the urgent trouble shooting the pump can be recovered from shutdown only by replacing the rotating PB assembly.



Construction and materials

Magnet Coupling Type : K Type

(MP210, 220, 221, 222, 420, 421, 541, 542)

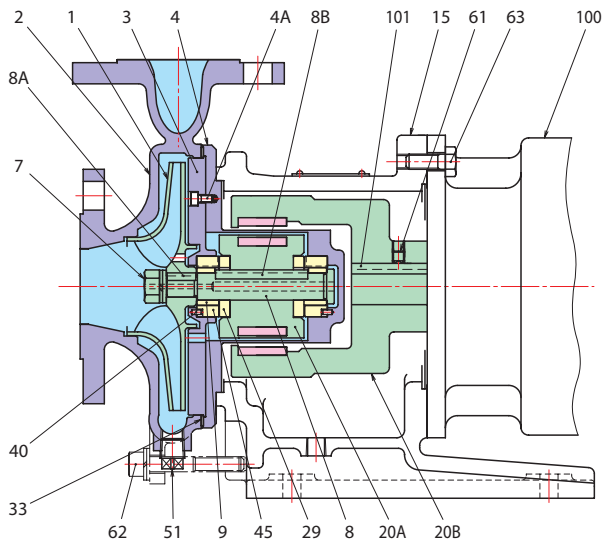

Magnet Coupling Type : V Type

(MP4220LF, 4220, 5225LF, 8415, 8420, 8515, 5430)

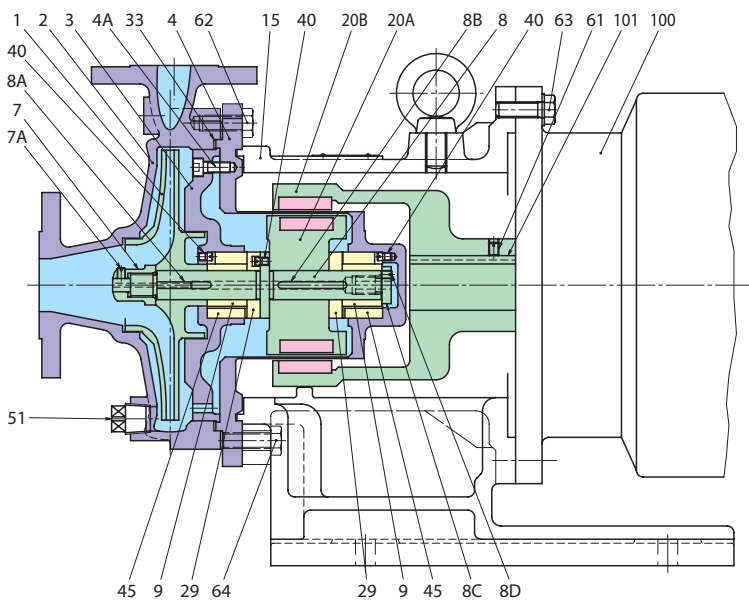

101	COUPLING KEY(M)	S45C	1
100	MOTOR	-	1
63	HEXAGON HEAD BOLT	304SS	4
62	HEXAGON SOCKET HEAD CAP SCREW WITH WASHER	304SS	6 ^S
61	SET SCREW	SCM435	1
51	PLUG	316SS	1
45	BUSHING	SiC	2
40	PIN	316SS	2
33	SHEET GASKET	PTFE	1
29	THRUST RING	SiC	2
20B	MAGNET MAGNET COUPLING(M)	RARE EARTH FCD	1 ^S 1
20A	MAGNET MAGNET COUPLING(P)	RARE EARTH FCD	1 ^S 1
15	FRAME ADAPTER	FC200	1
9	SLEEVE	SiC-D	2
8B	COUPLING KEY(P)	316SS	1
8A	IMPELLER KEY	316SS	1
8	SHAFT	316SS	1
7	IMPELLER NUT WITH WASHER	316SS	1 ^S
4A	HEXAGON SOCKET HEAD CAP SCREW	316SS	4
4	REAR CASING	316SS	1
3	CASING COVER	316SS	1
2	CASING	316SS	1
1	IMPELLER	316SS	1
MARK	NAME OF PART	MAT'L	No.REQ'D

101	COUPLING KEY(M)	S45C	1
100	MOTOR	-	1
64	HEXAGON HEAD BOLT	S5400	4
63	HEXAGON HEAD BOLT	S5400	4
62	HEXAGON HEAD BOLT	304SS	8
61	SET SCREW	SCM435	1
51	PLUG	316SS	1
45	BUSHING	SiC	2
40	SET SCREW	316SS	3
33	SHEET GASKET	PTFE	1
29	THRUST RING	SiC	2
20B	MAGNET MAGNET COUPLING(M)	RARE EARTH FCD	1 ^S 1
20A	MAGNET MAGNET COUPLING(P)	RARE EARTH FCD	1 ^S 1
15	FRAME ADAPTER	FC200	1
9	SLEEVE	SiC-D	2
8D	SLEEVE BOLT SET SCREW	316SS	1
8C	SLEEVE BOLT	316SS	1
8B	COUPLING KEY(P)	316SS	1
8A	IMPELLER KEY	316SS	1
8	SHAFT	316SS	1
7A	IMPELLER NUT SET SCREW	316SS	1
7	IMPELLER NUT	316SS	1
4A	HEXAGON SOCKET HEAD CAP SCREW	316SS	4
4	REAR CASING	316SS	1
3	CASING COVER	316SS	1
2	CASING	316SS	1
1	IMPELLER	316SS	1
MARK	NAME OF PART	MAT'L	No.

Significance of SiC-D

- Increased damage prevention -

- » SiC-D bearings can withstand accidental dry run for certain periods.
- » Unique materials and manufacturing techniques of our specially treated SiC-D bearings provide a coefficient of friction 1/4 that of SiC.
- » The very low coefficient of friction of our SiC-D bearings results in much less heat being generated in upset or dry running conditions. SiC-D bearings are more forgiving of dry running conditions frequently encountered at start up, during upset conditions or in batch services. Extremely hard surfaces minimize wear and prolong service life; resistance to chemicals is maintained for extended bearing life.

BUSHING (SiC)

THRUST RING (SiC)



SLEEVE (SiC-D)



Specifications

Pump Type	MP	
Frequency Hz	50	60
Max. Head m (ft)	80 (262)	120 (394)
Max. Capacity LPM (GPM)	1100 (290)	1300 (343)
Operating Temperature °C (°F)	-30 (-22) to 150 (302) See note1 below	
Maximum Specific Gravity	2	
Maximum Viscosity (mPa·s,cP)	300	
Design pressure (MPaG)	1,0 (1,2 and 1,6) See note2 below	
Flange standard	ASME / JIS / DIN flange	
Impeller type	Closed	
(Synchronized) rotation speed(rpm)	3000 / 3600	
Bore (Suction x Discharge) mm	25 x 20 to 80 x 50	
Motor Output kW	0,75 to 15	
Pump Material	Stainless Steel 316	

Note1: Below -20°C or above 120°C please contact your distributor.

Note2: Design pressure above 1,0 MPaG please contact your distributor.

Selection charts

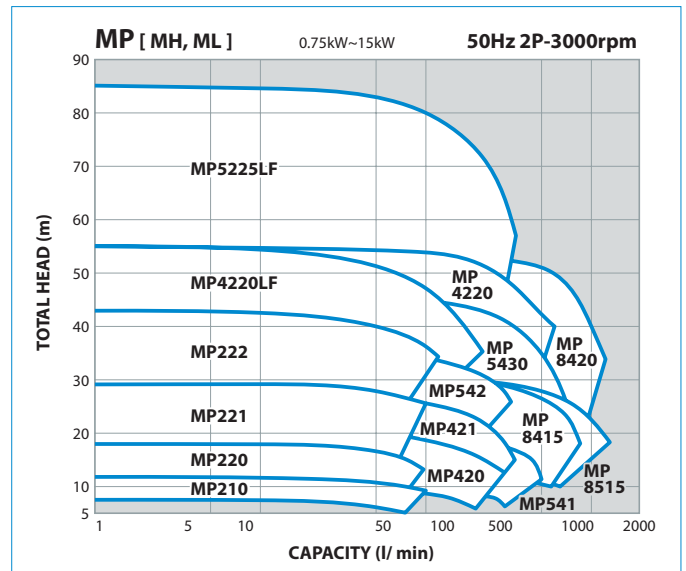
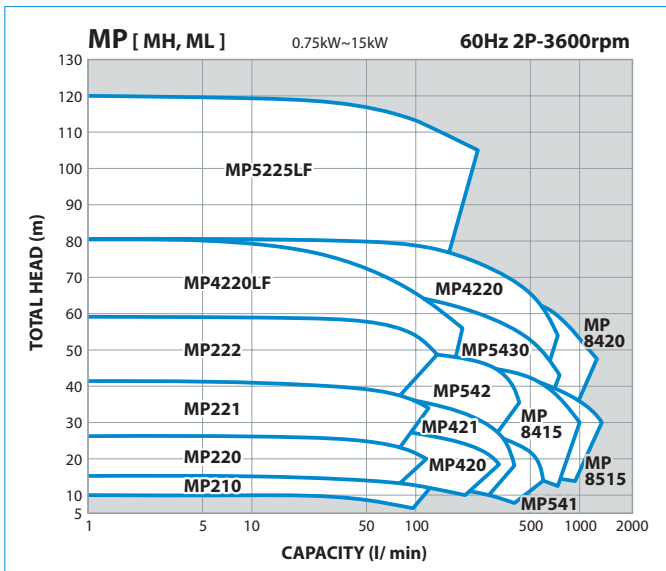

Pump Type Identification

MP222 - 170 - 6 KD F 022 K3290 D - 2 T1

[1] [2] [3] [4] [5] [6] [7] [8] [9] [10]

- [1] PUMP TYPE & SIZE
- [2] IMPELLER SIZE ; 80~255mm
- [3] WET-END MAIN MATERIAL ; "6": 316SS
- [4] MATERIAL OF BEARING ; "KD": SiC/SiC-D
- [5] TYPE OF MOTOR ; "F": FLANGE MOTOR
- [6] MOTOR OUTPUT ; "007": 0.75kW, "011": 1.1Kw, "015": 1.5kW, "022": 2.2kW, "040": 4kW, "055": 5.5kW, "075": 7.5kW, "110": 11kW, "150": 15kW
- [7] MAGNET COUPLING-MOTOR FRAME ; See Table.1
- [8] STANDARD FOR PIPE CONNECTION AND MOTOR ; "J": JIS10k RF FLANGE + IEC-MOTOR
"A": ASME150lb RF FLANGE + IEC-MOTOR
"D": DIN FLANGE + IEC-MOTOR
- [9] MOTOR POLE ; "2": 2POLE
- [10] SPECIAL CODE ; "(BLANK)": -20 ~ +120°C, "T1": +121 ~ +150°C, "T2": -30 ~ -21°C

Table.1

CODE	MAGNET COUPLING TYPE	MOTOR FRAME
K2680	K20x6	80M
K2090	K20	90L
K3290	K32	90L
K3211	K32	100L 112M
V2511	V25	112M
V4013	V40	132S/M
V4016	V40	160M/L
V6516	V65	160M/L

Outline dimension

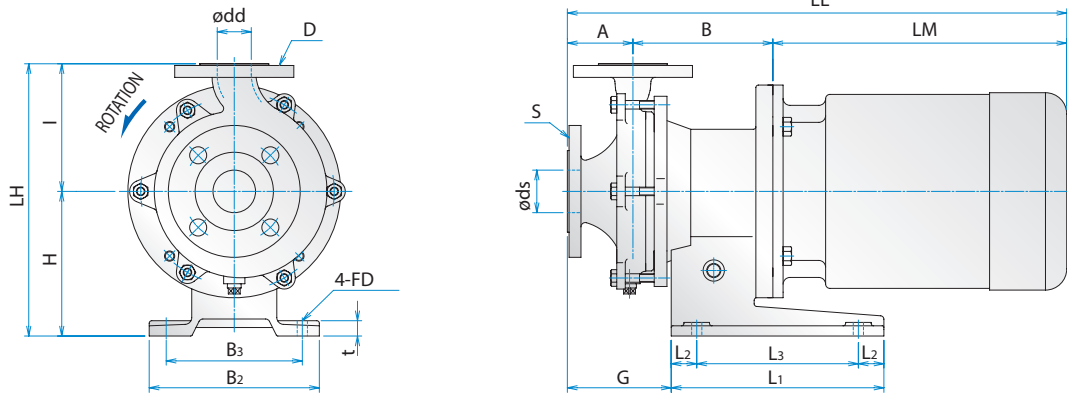

(Dimensions in mm)

PUMP SIZE	MOTOR		BORE				PUMP & MOTOR							BASE PLATE							MASS APPROX(kg)				
	FRAME SIZE	OUTPUT (kW)	SUCT ds	S	DISCH dd	D	A	B	H	I	LH	LM	LL	G	L1	L2	L3	B2	B3	t	FD	PUMP	MOTOR	TOTAL	
MP210	80M	0.75	25		20		80	170	110	110	220	233	478	125	180	30	120	160	130	12	ø12	22	12.5	34.5	
	90L	1.5					(75)				(105)	(215)	275									520	275	520	22
MP220	80M	0.75	25		20		60	170	110	120	230	233	463	110	180	30	120	160	130	12	ø12	23	12.5	35.5	
	90L	1.5											275									505	275	505	23
MP221	90L	1.5,2.2	25		20		65	170	130	300	275	505	110	250	30	190	200	160	18	ø12	27	18	45		
	(100L)112M	(2.2),3.7																			326	566	326	566	30
MP222	90L	1.5,2.2	25		20		65	170	140	310	275	505	110	250	30	190	200	160	18	ø12	29	18	47		
	(100L)112M	(2.2),3.7																			326	566	326	566	33
MP420	80M	0.75	40		25		75	170	170	135	305	233	478	125	250	30	190	200	160	18	ø12	29	12.5	41.5	
	90L	1.5,2.2											275									520	275	520	29
MP421	90L	1.5,2.2	40		25		75	170	135	305	275	520	125	250	30	190	200	160	18	ø12	30	18	48		
	(100L)112M	(2.2),3.7																			326	581	326	581	34
MP541	90L	2.2	50		40		80	170	140	310	275	525	130	250	30	190	200	160	18	ø12	31	18	49		
	(100L)112M	(2.2),3.7																			326	586	326	586	35
MP542	90L	2.2	50		40		65	165	170	150	320	275	505	110	250	30	190	200	160	18	ø12	34	18	52	
	(100L)112M	(2.2),3.7											326									566	326	566	38
MP4220LF	112M	3.7	40		25		102	258	212		377	355	715	175	350	50	250	250	200	20	ø15	68	47	115	
	132S,M	5.5,7.5						165	377	400	760	350	250									200	70	80	150
	160M,L	11,15							415	485	875	450	350									300	250	86	110
MP4220	112M	3.7	40		25		102	258	212		377	355	715	175	350	50	250	250	200	20	ø15	68	47	115	
	132S,M	5.5,7.5						165	377	400	760	350	250									200	70	80	150
	160M,L	11,15							415	485	875	450	350									300	250	86	110
MP5430	112M	3.7	50		40		102	258	212	170	382	355	715	175	350	50	250	250	200	20	ø15	72	47	119	
	132S,M	5.5,7.5					(165)	(377)	400	760	350	250	200									74	80	154	
	160M,L	11,15						(415)	485	875	450	350	300									250	90	110	200
MP8415	112M	3.7	80		40		102	258	212	170	382	355	715	175	350	50	250	250	200	20	ø15	72	47	119	
	132S,M	5.5,7.5					(165)	(377)	400	760	350	250	200									74	80	154	
	160M,L	11,15						(415)	485	875	450	350	300									250	90	110	200
MP8420	112M	3.7	80		40		102	263	212		427	355	720	180	350	50	250	250	200	20	ø15	74	47	121	
	132S,M	5.5,7.5						215	427	400	765	350	250									200	76	80	156
	160M,L	11,15							465	485	880	450	350									300	250	92	110
MP8515	112M	3.7	80		50		102	263	212		422	355	720	180	350	50	250	250	200	20	ø15	74	47	121	
	132S,M	5.5,7.5						210	422	400	765	350	250									200	76	80	156
	160M,L	11,15							460	485	880	450	350									300	250	92	110
MP5225LF	112M	3.7	50		25		102	263	212		427	355	720	180	350	50	250	250	200	20	ø15	84	47	131	
	132S,M	5.5,7.5						215	427	400	765	350	250									200	86	80	166
	160M,L	11,15							465	485	880	450	350									300	250	102	110

LM,LL dimensions and motor weight may vary depending on motor used.
Dimensions of A, I, LH in parentheses are for JIS and ASME.

Special versions:

For high temperature liquid
TYPE MH [RT~+280°C]

Fin type frame adapter dissipates heat away from pump.
Rare earth SmCo magnets are used and high temperature gasket material is used.

For low temperature liquid
TYPE ML [-80°C~+150°C]

Nitrogen purge port is provided to prevent moisture from freezing in the frame adapter. Rare earth Nd magnets are used as well as low temperature gasket material.

Iwaki pump protector - DRN series

Detects unusual pump operating conditions including dry-running and overload

The DRN pump protector is an electric current sensing dry running protector.

It decreases load current (lower limit) to stop the pump when it runs dry or runs with air sucking. The DRN pump protector detects over-load as well.



Specifications

Model	DRN-01	DRN-02
Amperometric range	0-30.00A	0-200.0A
Unit's source voltage	AC100-240V 50/60Hz 10VA	
Operating temperature	0-40°C	
Operating humidity	35-85%RH	
Current sensor	JS10FL	JS24FL
Analog input 1	0-20mA or 0-5V	
Analog input 2	0-20mA or 0-5V	
Temperature range	-50-200°C (Pt100, K thermocouple)	
Digital contact input	No-voltage contact signal (also for external reset)	
Contact output	For pre-alarm: AC250V 8A (load resistance) 1c For pump-stopping: AC250V 8A (load resistance) 1a	
Logging capability	Past records (with the calendar)	
Communication	RS485 incorporated	
Supported models	MX, SMX, MXM, MDM, MDE, MDW, MP, MTFO*	
External dimension in mm	D71 x W108 x H90	

*: For other models please contact your local distributor

Not used as an inverter.

Safety: UL 61010-1
CAN/CSA-C22.2 No. 61010-1-12
EN61010-1 EN61326-1, EN50581

EMC: EN61326-1
RoHS: EN50581



Please contact the Nordic IWAKI offices for questions and quotations:

IWAKI Danmark A/S

Rønnekrogen 2
DK-3400 Hillerød
Tel: +45 4824 2345
Fax: +45 4824 2346
Email: info@iwaki.dk
www.iwaki.dk

IWAKI Sverige AB

Enhagsslingan 21 A
SE-187 40 Täby
Tel: +46 (8) 511 729 00
Fax: +46 (8) 511 729 22
Email: info@iwaki.se
www.iwaki.se

IWAKI Finland Oy

Kultasepänkatu 4A
FI-04200 Kerava
Tel: +358 (9) 274 5810
Fax: +358 (9) 274 2715
Email: info@iwaki.fi
www.iwaki.fi

IWAKI Norge AS

Bjørnerudveien 13
NO-1266 Oslo
Tel: +47 2338 4900
Fax: +47 2338 4901
Email: info@iwaki.no
www.iwaki.no

Produced for IWAKI Pumps by:

SANWA HYDROTECH CORP.

11-33, Minamikaneden 2-chome, Suita, Osaka 564-0044, Japan.
Tel: 81-6-6330-5100 | Fax: 81-6-6330-4924