



AN SPX BRAND

Filter and Strainer Solutions for the Marine Industry



SPX®

Worldwide Experience in the Marine Industry

The Plenty brand has a tradition dating back to 1790 for the design and manufacture of quality engineered products.

Today Plenty is part of SPX, a leading international company supplying fluid handling equipment to many industries such as Oil, Gas, Petrochemical, Power and utilities. Within the large range of Plenty brand filters that SPX currently offers, we have developed a range of filter products specifically designed for the Marine Industry that offer a compact and lightweight solution to the many filtration requirements of modern vessels. SPX continues to maintain and develop the quality standards traditionally demanded by the Marine Industry and today is a UK Ministry of Defence, (M.O.D). approved and ISO 9001:2008 manufacturer.



Plenty Filters are currently supplied to many sectors of the Marine Industry such as:

- Naval
- Oil & Gas exploration and production
- F.P.S.O.'s
- Cruise Ships and Ferries
- Bulk liquid carriers
- Shore facilities (supporting all the above)

Naval - Plenty Filters are extensively used on all types of surface ships from minesweepers, frigates, destroyers and aircraft carriers along with conventional and nuclear submarines and is now considered a preferred range by the Royal Navy under Naval Engineering Standard NES 748.

With the Plenty Filters brand SPX has over 50 years experience supplying the British Royal Navy, satisfying the stringent requirements associated with equipment for warships. Our commitment to customer service extends to maintaining spares support for equipment that has now seen many years' service. Detailed records and equipment traceability combined with a commitment to customer support has resulted in spares still being available, enabling ships to remain in operation as long as required for countries including those in Asia, Australasia, Middle East and South America.



Oil & Gas Exploration and Production/ F.P.S.O's - In the Oil & Gas sector Plenty Filters are extensively used including the latest generation Floating Production Storage & Offloading vessels (FPSO's). Pipe laying (and testing) ships as well as Offshore Platforms.



Cruise Ships and Ferries - In addition to applications on more traditional designs, the cruise and ferry market is finding that for the

latest generation of fast ferries, the compact and lightweight design features that have made Plenty Filters a first choice on many naval designs are especially beneficial.

Bulk Liquid Carriers/ Shore facilities - Bulk Liquid Carriers and Shore Facilities have used Plenty Filters for many years with applications in bunkering including pump and meter protection as well as product transfer. Support vessels such as Auxiliary Oilers, Landing Platform Docks as well as Dock gates have all incorporated Plenty Filters in their designs.



Applications

Applications where Plenty Filters are utilised in the above sectors include:

- Sea water intake
- Cooling water
- Fire fighting water
- Hydraulic oil filtration
- Fuel oil filtration
- Product transfer systems



SPX's range of Plenty Filters are especially suited to marine applications and is supported by a comprehensive range of products from our wider range for general industry and commercial usage. Experience in these other industries benefits Marine applications as this enables products to be adapted and customised or purpose built for specific duties.

Plenty filters are readily available constructed in materials from cast iron and steel to stainless steel and aluminium bronze or gunmetal. Special

coatings or alloys such as Cupro Nickel, Duplex and Super Duplex stainless steels can be provided to meet design requirements. The filter elements are also available in a range of corrosion resistant materials for long life. Simplicity is common to all Plenty filter designs which leads to ease of operation, robust construction and long equipment life.

- No special tools are required for normal operating procedures, and in many cases equipment is entirely hand operated for filter maintenance ensuring operating standards can be easily maintained.
- The special marine products are designed to occupy the minimum space whilst still maintaining the highest performance standards
- Combined with the ease of operation, this enables the equipment to be located and maintained even in the most confined of spaces frequently encountered in engine rooms.



For the Marine Industry Plenty filters are able to satisfy special requirements including:

- Shock testing - Plenty brand equipment has been tested and certified to withstand shock loading and can be fitted with shock fixing points.
- Non Magnetic testing – Plenty brand equipment has been approved to meet the anti magnetic requirements of the UK and international naval defence standards.

Simplex



- Easy opening cover that does not require any tools
- Can be used on any liquid (Oil, Fresh & Sea Water and Gas)
- Available in wide range of pipe sizes 25mm (1") to 300mm (12")
- Materials of construction including;
 - Cast iron
 - Cast steel
 - Stainless steel
 - Gunmetal/Aluminium Bronze
 - Specialised metals on request
- Can be supplied with elements for filtration to 45 micron
- Suitable for high pressure systems
- Gunmetal or aluminium bronze suitable for shock and non-magnetic service



Simplex Type S Filter 1" to 1½" (25-40 mm) Flanged

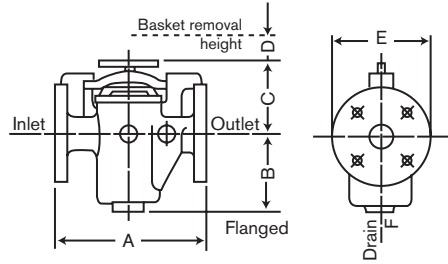

Size	(Bore)	Model	A	B	C	D	E	F	Weight	
Imp	mm	no.	mm	mm	mm	mm	mm	BSPT	lb	kg
1"	25	SN-1	197	98	102	14	124	½"	18	8
1½"	40	SN-1.5	216	149	102	73	156	½"	28	12.5

Note: Screwed ends also available in some materials.

Simplex Type S Filter 2" to 8" (50-200 mm)

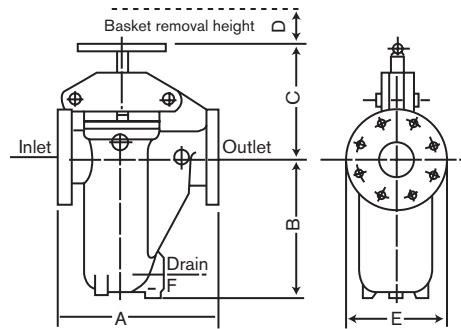

Size	(Bore)	Model	A	B	C	D	E	F	Weight	
Imp	mm	no.	mm	mm	mm	mm	mm	BSPT	lb	kg
2"	50	SN-2	292	192	198	122	165	1¼"	51	23
3"	75	SN-3	362	270	251	138	210	1¼"	101	45
4"	100	SN-4	425	371	297	120	254	1½"	181	82
6"	150	SN-6	584	514	349	260	318	1½"	435	197
8"	200	SN-8	711	698	492	350	381	1½"	800	364

Simplex Type S Filter 10" to 12" (250-300 mm)

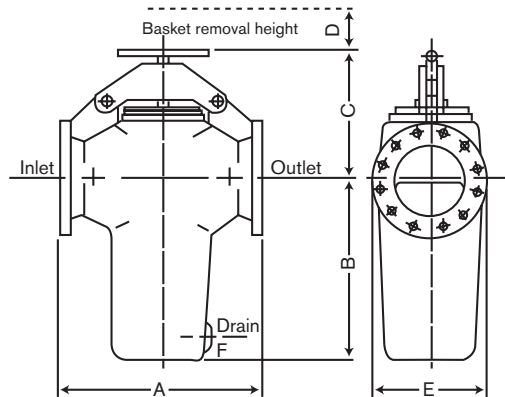

Size	(Bore)	Model	A	B	C	D	E	F	Weight	
Imp	mm	no.	mm	mm	mm	mm	mm	BSPT	lb	kg
10"	250	SN-10	864	790	625	673	457	2"	990	450
12"	300	SN-12	864	790	625	673	521	2"	1070	486

Filmet



Similar to Simplex but with a larger element to give low pressure loss and/or handle high flows.

- Available in pipe sizes from 20mm (3/4") to 85mm (2 1/2")
- Materials including;
 - Cast iron
 - Cast steel
 - Stainless steel
 - Gunmetal/Aluminium Bronze
 - Specialised metals on request
- Can be supplied with elements for filtration to 45 micron
- Suitable for medium pressure systems
- Gunmetal or aluminium bronze suitable for shock and non-magnetic service

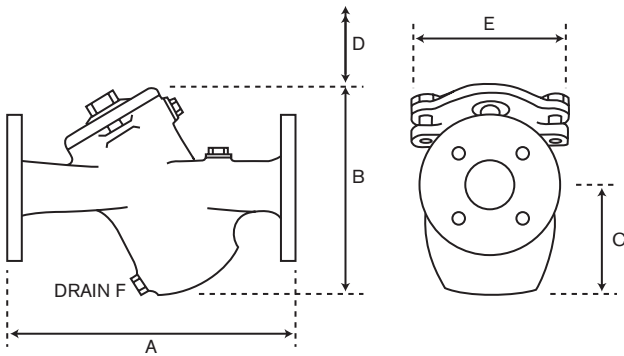

Size	(Bore)	A	B	C	D	E	F	Weight	
Imp	mm	mm	mm	mm	mm	mm	BSP.PAR	lb	kg
3/4"	20	227	143	83	50	133	1/4"	16	7
1"	25	229	172	83	50	140	1/4"	16	7
1 1/2"	40	258	194	105	75	143	1/4"	20	9
2"	50	352	268	145	100	175	1/4"	31	14
2 1/2"	65	365	268	145	100	175	1/4"	33	15

Seaguard



Normally supplied in Gunmetal or Aluminium Bronze with a Cupro-Nickel screen, it is suitable for low or medium pressure applications such as sea water cooling, fire fighting applications, hydraulic and fuel oils and product transfer. The Plenty Seaguard is ideally suited for shock and non magnetic service.

- Compact lightweight design
- Easy opening cover does not require any tools
- Very low pressure loss, suited to high flow rates
- Available in wide range of pipe sizes 50mm (2") to 500mm (20")
- Normally supplied in gunmetal or aluminium bronze and suitable for low or medium pressure systems
- Suitable for shock and nonmagnetic service
- Fabricated versions also available in a range of materials on request

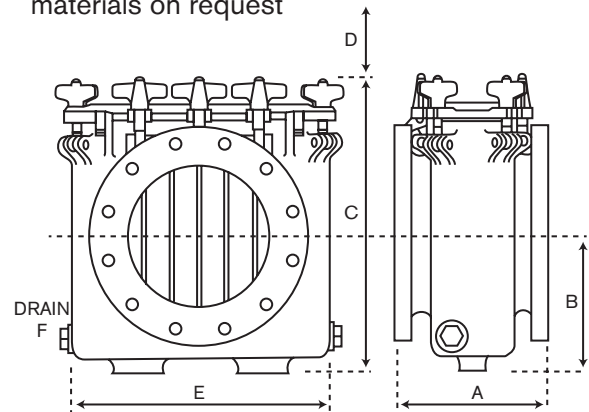

Size	(Bore)	A	B	C	D	E	F	Weight	
Imp	mm	mm	mm	mm	mm	mm	BSP.PAR	lb	kg
2"	50	290	90	225	105	235	3/8"	49	22
2 1/2"	65	307	100	250	145	235	1/4"	60	27
3"	80	308	100	250	145	235	3/8"	62	28
4"	100	315	169	367	185	304.8	3/4"	123	56
5"	125	385	178	395	235	370	3/4"	182	97
6"	150	378	178	395	235	370	3/4"	91	105
8"	200	386	247	538	336	370	3/4"	275	148
10"	250	279	274	580	425	515	1 1/2"	336	160
12"	300	495	220	610	445	645	1"	407	184
14"	350	505	338	691	498	715	1 1/4"	478	217
16"	400	502	366	756	573	730	1 1/4"	661	300
20"	500	294	473	943	749	856	1 3/8"	710	322

Duplex (Small)

A dual basket filter designed for installation in pipe systems operating continuously

- Incorporates 100% standby and internal flow diverting valve operated by single lever
- Compact design
- Available in pipe sizes from 25mm (1") to 100mm (4")



Duplex (Large)

Similar to small duplex with 100% standby and integral valves to give compact assembly the larger sizes, the valve is operated by crank handle or wheel.

- Available in wide range of pipe sizes 150mm (6") to 500mm (20")

Materials including;

- Cast iron
- Cast steel
- Stainless steel
- Gunmetal/Aluminium Bronze
- Specialised metals on request
- Can be supplied with elements for filtration to 45 micron
- Suitable for low or medium pressure systems
- Gunmetal or aluminium bronze suitable for shock and non-magnetic service

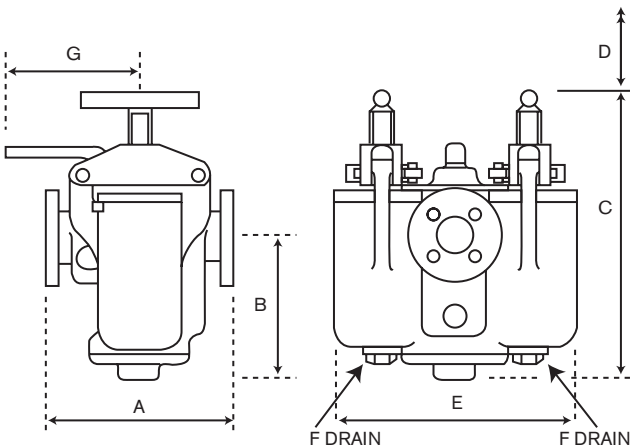

Size	(Bore)	A	B	C	D	E	F	G	Weight	
Imp	mm	mm	mm	mm	mm	mm	BSP.PAR	mm	lb	kg
1"	25	270	210	410	70	343	3/4"	203	121	44
1 1/2"	40	264	210	410	70	343	3/4"	203	123	66
2"	50	273	205	410	70	343	3/4"	203	125	57
2 1/2"	65	305	257	470	70	387	1 1/4"	203	181	86
3"	80	349	290	577	68	464	1 1/4"	305	277	126
4"	100	445	384	572	165	673	1 1/2"	381	510	231

Materials including;

- Cast iron
- Cast steel
- Stainless steel
- Gunmetal/Aluminium Bronze
- Specialised metals on request
- Can be supplied with elements for filtration to 45 micron
- Suitable for low or medium pressure systems
- Gunmetal or aluminium bronze suitable for shock and non-magnetic service

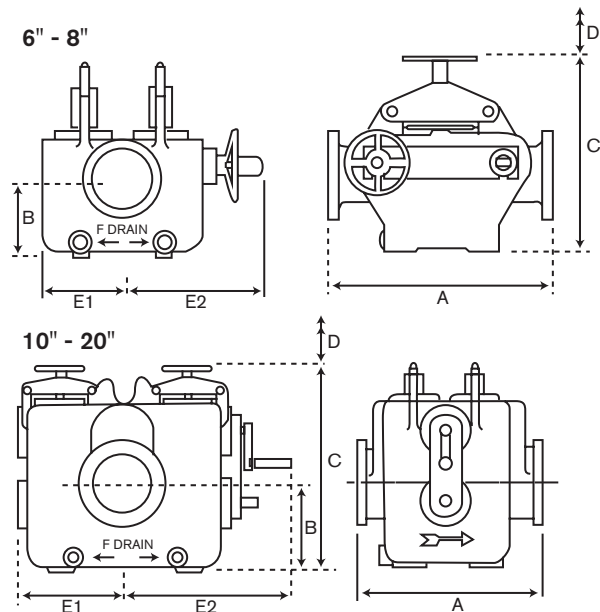

Size	(Bore)	A	B	C	D	E1	E2	F	Weight	
Imp	mm	mm	mm	mm	mm	mm	mm	BSP.PAR	lb	kg
6"	150	835	343	736	356	401	705	1 1/2"	1003	454
8"	200	1016	343	825	356	401	705	1 1/2"	1342	601
10"	250	1026	356	991	483	619	864	1 1/2"	3010	1368
12"	300	1029	381	991	483	619	864	1 1/2"	3080	1398
16"	400	1260	559	1346	889	702	1032	1 1/2"	5264	2390
18"	450	1270	584	1346	889	702	1032	1 1/2"	5340	2426
20"	500	1270	610	1346	889	702	1032	1 1/2"	5420	2460

SPX offers a range of Industrial Filtration Solutions for multiple process industries worldwide. Products include: Simplex and Duplex cast and fabricated strainers, Self-Cleaning and Back-Flushing strainers, High Pressure Gas Filters, and Fabricated Bathtub strainers. All equipment is available in a variety of materials and design codes, and are all Pressure Equipment Directive (PED 97/23/EC) compliant.



OV SINGLE & OW DUAL BASKET STRAINERS

OV Single Basket Strainers

- Used for filtering liquids when flow can be interrupted for cleaning
- Line sizes from 3/4" to 10" NB and available with screwed and flange connections
- Available in a wide range of materials to suit the application
- OV & OW multi-basket designs available, filtration levels from 10mm down to 10 micron
- Standard range designed for a maximum rating of 22 Barg (material dependant), high pressure options (50 Barg) available

OW Dual Basket Strainers

- Used for filtering liquids when flow cannot be interrupted for cleaning
- Handle selects between operating chamber, allowing safe removal of basket from isolated chamber while filter is still in operation
- Optional 100% shutoff facility to eliminate any leakage between chambers



SELF CLEANING FILTERS

- Positive scraping action efficiently cleans element while independent debris removal minimises fluid loss without process interruption
- Stainless steel wedge-wire or perforated elements provide filtration from 3mm down to 25 micron
- Used where an automatic cleaning strainer is required even with low pressures
- Ensures process continuity without manual labour or contact with hazardous materials



BACKFLUSH STRAINER

- Used where an automatic cleaning strainer is required
- Ensures process continuity without manual labour
- Provide a high level of cleaning efficiency with minimal product loss
- Straining element is manufactured from stainless steel 316
- Fine mesh lined baskets provide capabilities for particle removal down to 50 micron



GAS FILTRATION

- Designed to remove solids from gas streams
- Elements include cleanable stainless steel or disposable fiberglass or polypropylene
- High pressure rated to Fas PD5500/ E13 & ASME VIII specification
- Quick opening or bolted closures
- Designed to meet customers operating conditions



Your local contact:



SPX Flow Technology
Hambridge Road, Newbury, Berkshire, RG14 5TR
Phone: +44 (0) 1635 42363 Fax: +44 (0) 1635 49758
Email: plentyfilters@spx.com
www.plentyfiltration.net
www.spxft.com

For more information about our worldwide locations, approvals, certifications, and local representatives, please visit www.plentyfiltration.net.

SPX Corporation reserves the right to incorporate our latest design and material changes without notice or obligation. Design features, materials of construction and dimensional data, as described in this bulletin, are provided for your information only and should not be relied upon unless confirmed in writing.

Issued: 08/2010

Copyright © 2010 SPX Corporation