

# System Catalog 3

Solenoid valves | Process and control valves | **Pneumatics**

Sensors | MicroFluidics | MFC and proportional valves



The smart choice of Fluid Control Systems



# Contents

<b>1. Application examples for pneumatics</b>	
<b>2. What is pneumatics?</b>	
2.1. Typical application areas of pneumatics	Page 10
2.2. Examples of application areas utilizing pneumatics	Page 10
2.3. Compressed air operating medium	Page 11
2.4. Important properties of air	Page 11
<b>3. Elements of a compressed air system</b>	
3.1. Compressed air generation	Page 12
3.2. Compressed air conditioning	Page 12
3.2.1. Service units for compressed air	Page 12
3.2.2. Compressed air filter	Page 13
3.2.3. Pressure controller	Page 13
3.2.4. Compressed air lubricator	Page 14
3.3. Compressed air utilization	Page 14
3.3.1. The general pneumatic actuator	Page 14
Classification of actuators	Page 15
3.3.2. Pneumatic cylinders	Page 15
3.3.2.1. Design and circuit functions of a pneumatic cylinder	Page 15, 16
Single-acting cylinders	Page 16
Double-acting cylinders	Page 16
3.3.3. Actuators for pneumatic process valves	Page 16
3.3.3.1. Piston actuators for on/off process valves/ ON/OFF valves	Page 16
Single-acting piston actuators	Page 17
Double-acting piston actuators	Page 17
3.3.3.2. Piston actuators for globe valves or angle-seat valves	Page 17
3.3.3.3. Piston actuators for diaphragm valves	Page 17
3.3.3.4. Diaphragm actuators for globe valves	Page 18
3.3.3.5. Rotary actuators for butterfly valves and ball valves	Page 18
3.3.4. Selection criteria for pneumatically operated process valves	Page 18
Control functions for process valves	Page 18
Flow direction and water hammer	Page 18
Pilot pressure and operating pressure	Page 19
Medium and ambient conditions	Page 19
Port connections	Page 19
Torques	Page 19
3.4. Compressed air "disposal"	Page 19
<b>4. Dimensioning</b>	
4.1. Selection criteria for pneumatic cylinders	Page 20
Piston force	Page 20
Forces on the single-acting cylinder	Page 20
Forces on the double-acting cylinder	Page 20
Load of the piston rod, stroke length	Page 20

Piston speed	Page 20
Air consumption (energy costs)	Page 20
Connection facilities, supply lines and cylinder port sizes	Page 20
Installation and ambient conditions	Page 20
4.2. Pilot valves for pneumatic actuators	Page 21
4.2.1. Spool valves	Page 21
4.2.2. Seat valves	Page 22
4.2.3. Circuit functions and possible applications of multi-way solenoid valves	Page 26
4.2.4. Selection criteria for multi-way valves	Page 27
Actuators, circuit function	Page 27
Selection of pilot valves (multi-way valves), allowing for the air capacity	Page 27
4.2.5. Example pilot valve applications for controlling process valves	Page 28
4.2.6. Installation location and method for pilot valves	Page 28
4.2.7. Examples of multi-way valves	Page 30
4.2.8. Selection criteria for pilot valves and pilot valve units	Page 35

## **5. Pneumatics in automation engineering**

5.1. Factory automation	Page 36
5.2. Process automation	Page 36

## **6. Flow valves, shut-off valves and accessories**

6.1. Restrictor valves and flow control valves	Page 37
6.2. Check valves or shut-off valves	Page 38
6.3. Quick-exhaust valves	Page 38
6.4. Shuttle valves or OR-element	Page 38
6.5. Accessories	Page 39
Plastic tubes	Page 39
Mufflers	Page 39
Screwed fittings	Page 39
Plug-in fittings	Page 39
Compression fittings	Page 39
6.6. Selection criteria for flow valves, shut-off valves and accessories	Page 39

## **7. Control signals for pilot valves**

Direct control	Page 40
Fieldbus technology	Page 40

## **8. Pneumatics search trees**

8.1. Single valves, multi-way valves	Page 42
8.2. Valves for direct mounting on the actuator	Page 43
8.2.1 NAMUR valves	Page 43
8.2.2 Pilot valves	Page 44
8.3. Valve blocks	Page 45

8.4. AirLINE / valve islands with fieldbus interface	Page 46
8.5. Cylinders	Page 48
8.6. Service units	Page 48
8.7. Flow valves and shut-off valves	Page 49
8.8. Accessories	Page 49

## **9. Glossary**

Current consumption of AC solenoids	Page 50
Current consumption of DC solenoids	Page 50
Direct-acting valves	Page 50
Duty cycle	Page 50
Electrical control cabinets and solenoid valves	Page 50
Flow direction in solenoid valves	Page 50
Flow rates $K_v$ and $Q_{Nn}$	Page 51
Heating of solenoid valve coils	Page 51
Intermediate infeeds in the case of valve blocks or valve islands with fieldbus interface	Page 51
Manual overrides	Page 51
Mufflers	Page 51
Operating voltages, voltage tolerances	Page 52
Pilot valves response times	Page 52
Pressure information	Page 52
Push-over solenoid coils	Page 52
Selecting a valve	Page 53
Service life, lubrication and wear	Page 53
Servo-assisted valves	Page 53
Simultaneity factor on valve islands with fieldbus interface	Page 53
Switching errors due to congestion in the exhaust duct	Page 54
Temperature ranges for pneumatic solenoid valves	Page 54
Valve replacement in ongoing operation	Page 54

# Systematic compressed solutions



## The pressure is on for automation

Its particularly high reliability when generating high forces, torques and powers make pneumatics indispensable for efficient solutions pertaining to drives/actuators and measurement, control and regulation. Bürkert technology is more than a match for any “pressure” put on it in the future. Regardless of whether it is state-of-

the-art robot technology for production pneumatics, filling systems, mixing systems and dosing systems for process engineering or actuators for mechanical engineering: users in an extremely wide variety of industries throughout the world rely on “progress made by Bürkert”. We don’t mind the pressure of success at all. That results in new standards in automation using compressed air.





## **Technical evolution means adaptation**

Central or distributed: not a question of faith in automation. Every problem is different and requires the most efficient solution. Distributed pneumatics is generally the better solution in factory automation having constantly recurring work steps and short cycle times. In contrast, process automation, as is demanded by the food, chemical

and pharmaceutical industries, with their complex installations, requires a high level of decentralization and e.g. easy conversion or expansion during operation. The magic phrase is “technology in tune with demand”. Bürkert has perfected this “pneumatics music” with its practically-oriented competence.

# A blockbuster



## Brought in line

For a long time now, pneumatics has not been simply a “hermetically” sealed system of efficient solutions using exclusively compressed air. With its AirLINE system, Bürkert has gone beyond the boundaries and created a combination of pneumatics and electrical engineering that provides new perspectives in automation.

Digital and analog input and output modules are mounted on a rail together with pneumatic valve controls and can be connected using a fieldbus to produce a distributed system with all the advantages of compact design and flexibility. This is just one example of many, providing a convincing answer as to why you should rely on Bürkert for your pneumatics.





A complex system solution is not always required in every case. You are looking for the appropriate pneumatic component, i.e. a specific valve or a valve island with fieldbus interface. It is good to know that when doing this, you can rely on the quality of a market leader. Millions of load cycles are the criterion for faultless operation and long service life of a Bürkert manufactured valve or valve block with a fieldbus interface.

And to meet every requirement, this also applies to all our pneumatics products. With our decades of experience and broad product range in line with market requirements for almost any application, we are your “blockbuster” for specific solutions to problems. You can rely on this – and look confidently to the future.

## 2. What is pneumatics?

Pneumatics is a sub-area of fluidics. The term pneumatics is derived from the Greek word "pneuma". Pneuma means wind, breath, spirit or invigorating (divine) power.

Today, the term pneumatics means technical utilization of pressurized gases, in particular compressed air. Pneumatics has been used for many decades to perform a variety of tasks.

### Utilization areas of pneumatics

- Generation of forces and torques for actuation and positioning, i.e. intervention in processes
- Generation of movements for transporting unit loads and parts
- Transporting pourable substances in pipes
- Detecting, transmitting, processing and using information.

The areas of utilization clearly indicate that pneumatics can be used to perform both energy-related and information-related tasks. With the rapid developments in the field of micro electronics, the application of pneumatic components for information processing is now on the decline.

### 2.1. Typical application areas of pneumatics

include actuators for the following tasks, among others:

- machine tools and tools
- conveying systems
- valves and fittings
- processing machines
- automotive engineering
- robotics and manipulators

as well as

measurement, control and regulation equipment, e.g. for:

- pneumatic drives and actuators
- processes in process engineering and processing
- processes in production engineering and robotics.

Due to its **special characteristics** as compared to other technologies such as electrical engineering, electronics, mechanics and optics, pneumatics has assumed a fixed position in technology. Important reasons for this are its:

- insensitivity to ambient influences
- clear structure
- high reliability and long service life
- generation of high forces, torques and powers
- ability to handle high actuating speeds
- relatively low procurement costs with feasible operating costs
- the fact that it involves no risk of fire or explosion
- easy coupling to electrical and electronic technologies.

### 2.2. Examples of application areas utilizing pneumatics

#### Manipulators

##### (production pneumatics)

- Robots and manipulators
- Clamping workpieces
- Moving/transporting workpieces
- Loading/positioning workpieces
- Branching the flow of unit loads
- Separating workpieces
- Driving axes and shafts
- Changing the position of workpieces
- Embossing and pressing workpieces
- Packaging
- Stacking workpieces
- Opening and closing doors.

#### Actuators/valves for process engineering

- Filling
- Mixing
- Dosing
- Shutting off/locking
- Continuous material transport.

### Actuators/drives for mechanical engineering

- Hammer drills
- Machine tools
- Packaging machines
- Woodworking machines
- Gauging machines
- Transport machines
- Sorting machines.

### 2.3.

#### Compressed air operating medium

- The compressed air operating medium is available in unlimited quantities.
- Many plants have their own compressed air systems / compressed air networks.
- The pressure range normally lies between 5 and 8 bar.
- Compressed air is easy to transport and easily stored.
- Compressed air that is not required can be vented into the atmosphere.
- No return line for the energy-carrying medium to the compressor.
- No environmental pollution if unlubricated compressed air is used.
- No risk of fire or explosion.

### 2.4.

#### Important properties of air

- Air has a specific gravity of 1,293 kg/m<sup>3</sup> bei + 20 °C and standard pressure.
- Air is a mixture of gases containing approx. 78 % N<sub>2</sub>, 21% O<sub>2</sub> and traces of other gases (CO<sub>2</sub>, H<sub>2</sub>O, He and others).
- Air is able to absorb only a maximum amount of water vapor dependent on temperature.
- The higher the temperature, the more water vapor air can absorb.
- With dropping temperatures, the air releases the water vapor again in the form of condensate.



Type 8644-Siemens



Type 6518

# 3. Elements of a compressed air system



A compressed air system comprises components for:

- compressed air generation
- compressed air conditioning
- compressed air utilization
- compressed air disposal.

## 3.1. Compressed air generation

In order to generate compressed air, the compressor, driven by an electric motor or internal-combustion engine, inducts air through a filter, compresses it to 6 to 10 bar and forces it – frequently via an intercooler – into a compressed air reservoir. The compressed air flows from the compressed air reservoir into the line network. In order to be able to compensate for pressure losses in the system, the compressor generates a pressure lying approx. 1.5 to 2 bar above the required operating pressure. The compressed air reservoir equalizes the compressed air fluctuations resulting from air consumption in the system.

For reasons of safety, pressure relief valves are connected downstream of a compressed air generator in order to limit the pressure in the compressed air reservoir. An air line is generally designed as a ring line and split into individual system sections by means of shut-off valves, in order to be able to depressurize the sections for repair or maintenance purposes without having to shut down the entire system.

## 3.2. Compressed air conditioning

The purpose of compressed air conditioning is to achieve compressed air

- that is largely free of foreign bodies, foreign matter and water. Water increases the risk of corrosion, combines with oil to form emulsions and thus impairs the antifric-tion properties of moving parts
- that is adjusted to the required operating pressure
- which either contains or does not contain lubricant (depending on technological requirements).

### 3.2.1. Service units for compressed air

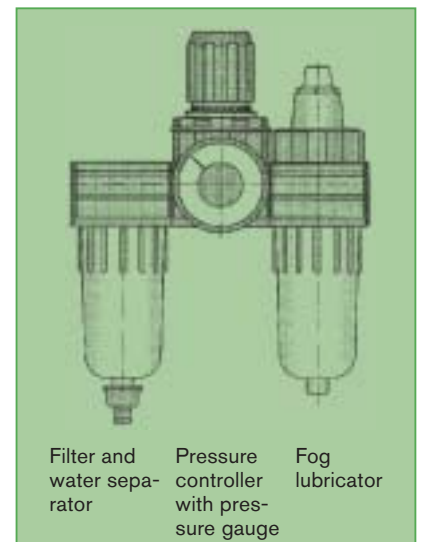

With the aid of a service unit, the compressed air taken from the network is conditioned for utilization in a pneumatic application. The quality requirements pertaining to compressed air generally depend on the device and manufacturer.

A service unit consists of the following components:

- filter hood with filter element for cleaning the compressed air
- pressure controller with pressure gauge for controlling and indicating the pressure
- oil hood with lubricator (optional) for lubricating the compressed air if required.

Service units have various designs, depending on the flow rate and port connection.

Circuit symbol of a complete service unit consisting of filter with water separator and manual drain, pressure control valve with pressure gauge and fog lubricator (representation in accordance with DIN 1219-1).

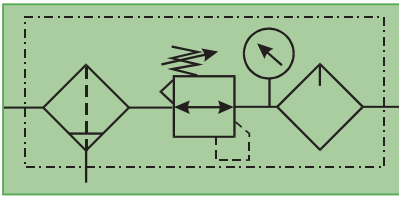

### 3.2.2. Compressed air filter

In the filter, the compressed air initially flows against a spin disk which causes the air to rotate. The centrifugal force sorts out the water particles and solid foreign matter, spins them against the inside wall of the filter and collects them in the lower section of the filter bowl. The thus pre-cleaned air is discharged through the filter cartridge. The filter cartridge also sorts out any dirt particles larger than the pore size in order to protect very fine ducts and nozzles, etc. against dirt.

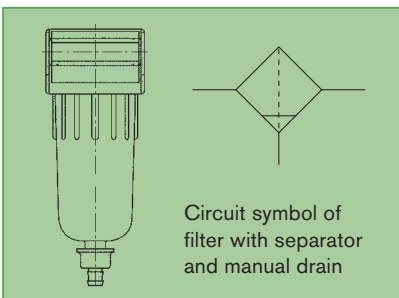

### Selection criteria

- Required mesh aperture (pore size)
- Max. air demand
- Max. input pressure
- Connection facility (facilities)

### Servicing

- Clean the filter cartridge regularly or change it since increasing dirt build-up increases the flow resistance and thus reduces the throughput.
- Drain off the condensate when the condensation mark is reached (ideally, you should use a filter with an automatic condensate drain).

### 3.2.3. Pressure controller

The controller has the task of maintaining the pressure of the air taken from the network at a constant value. The controller can operate only if its input pressure (primary pressure) is higher than the required output pressure (secondary pressure). The pressure is controlled in the pressure controller by an equilibrium of forces at a diaphragm. The outlet pressure is applied to one side of the diaphragm. A spring is fitted on the other side and its force of compression (set-point value) can be adjusted to any value with the controller's rotary knob. When the outlet pressure rises, the diaphragm moves against the spring force. This changes the passage cross-section at the valve seat so that it adjusts the inflowing quantity until the preset pressure is reached. The valve closes at pressure equilibrium. If air is removed, the operating pressure drops, the spring force opens the valve and air is replenished until an equilibrium of pressure is achieved, etc., i.e. the control valve is opened and closed constantly.

A cushioning system is installed above the valve disk to prevent the occurrence of flutter phenomena. The pressure control valve is connected downstream of the compressed air filter.

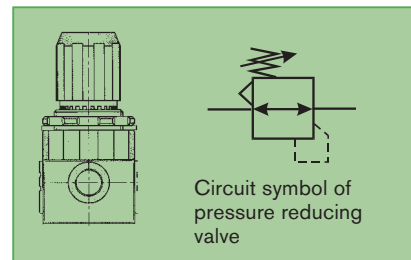

### Selection criteria

- Existing input pressure (primary pressure)
- Required output pressure (secondary pressure, operating pressure)
- Required air flow rate.

### Servicing

- The pressure controller requires no maintenance if it is connected downstream of the compressed air filter.



### 3.2.4. Compressed air lubricator

Lubricated air should only be used in exceptional cases. It contaminates the lines, can cause seals and drive elements/actuators to jam and the lubricant must be separated off again before venting the pilot air back into the atmosphere.

Most of today's control valves and actuators already operate with self lubrication or require no lubrication, i.e. they operate with unlubricated air. Under certain operating conditions, lubrication of the compressed air is required, such as with fast sequences of movement in cylinders or bearings. In this case, the compressed air flows through the lubricator and generates a partial vacuum when it passes through a constriction in the cross-section. This partial vacuum inducts oil from the supply reservoir via a riser. The oil is routed into a drip chamber, atomized by the air stream and transported along with the air stream.

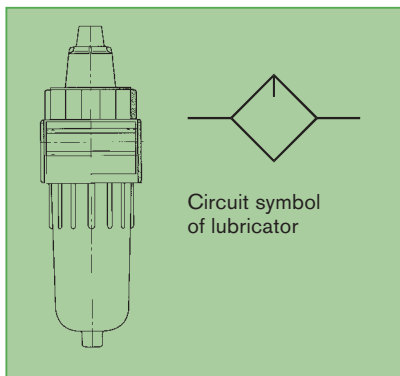

#### Selection criteria

- Maximum flow rate
- Minimum flow rate
- Max. operating pressure
- Port connection
- Number of lubrication points and spacing between them.

#### Note

Oil precipitation on the inside pipe walls leads to contamination of the compressed air line and causes components to jam, particularly after long downtimes. Consequently, the oil quantity should be restricted to the absolute minimum required.

## 3.3. Compressed air utilization

When using compressed air, the general application is for a force to be generated in an actuator through the effect of the air pressure on a surface (piston or diaphragm), and this force is then used to move the control or actuating elements – frequently against a spring force. A broad variety of technical solutions exist for the individual applications that utilize compressed air.

### 3.3.1. The general pneumatic actuator

A pneumatic actuator consists of a control unit, generally with converter function, a pneumatic actuator (cylinder-piston actuators, diaphragm actuators or rotary actuators) and a final control element (valve or transport device), in addition to various accessories. The control unit is primarily driven via low-energy input signals (e.g. electrically, pneumatically or mechanically operated control valves with pneumatic output / actuating signal). The final control element linked to the actuator is actuated by the travel, angle or force and intervenes directly in the process being controlled (flow of fuel, mass flow or part flow).

### General design of a pneumatic actuator

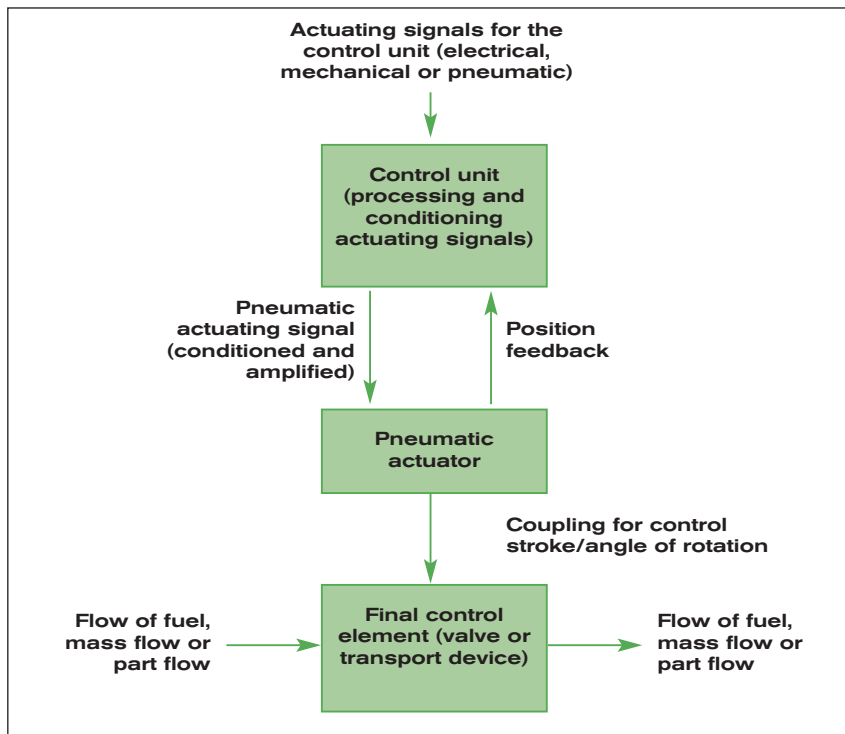

### Classification of actuators

In the actuator, the pneumatic actuating signal is converted to a travel and/or force for driving a final control element. The most conventional actuators are as follows:

- Translatory actuators (linear motors)
  - Cylinder-piston actuators
  - Diaphragm actuators.
- Rotary actuators (torque motors)
  - Rotary actuator (up 180°)
  - Torque motors (turbine drives).

### 3.3.2. Pneumatic cylinders

Pressure energy is converted to kinetic energy (force and velocity) in pneumatic cylinders. The basic form of pneumatic cylinder consists of a cylindrical barrel and a piston with piston rod. In operational state, they execute linear movements (linear actuators) for travels ranging from a few centimeters to several meters and execute actuating forces up to over 10,000 N depending on the type of construction (flow rate, stroke and piston diameter). Pneumatic cylinders may be optionally equipped with end of stroke cushioning and additionally with restrictor valves in order to cushion abrupt loads when the end positions are reached. The operating pressure lies in the range 1 to 10 (or 16) bar.

Pneumatic cylinders are rugged actuators with a long service life. They are used primarily in production engineering for transport and handling. They are particularly suitable for lifting, lowering, sliding, clamping, guiding, beating, pulling, swiveling, pushing, latching, folding and for actuating valves.

#### 3.3.2.1. Design and circuit functions of a pneumatic cylinder

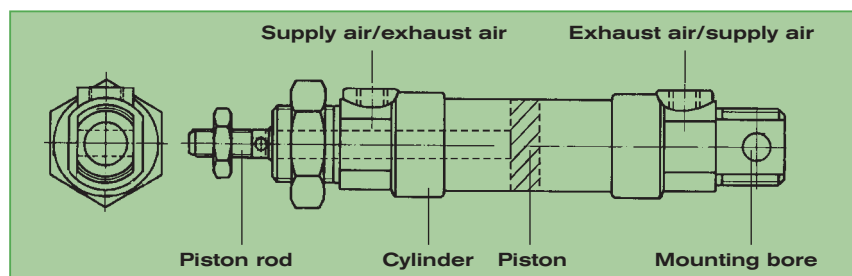

### Single-acting cylinders

The movement is produced by the action of the compressed air in the operating volume on the piston against the spring force. The air located in the spring chamber escapes via an open duct. After the operating volume has been relieved, the spring pushes the piston back to the initial position. During this process, the operating volume escapes via the inlet duct. A 3/2-way valve is used as the control unit.

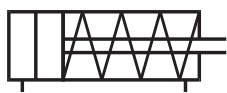

Circuit symbol of single-acting cylinder

### Double-acting cylinders

The movement in both directions is produced by the action of compressed air. It is possible to implement differing speeds for the forward and return movement by varying the restriction of the inflowing and outflowing air. In this case, filling and venting are performed via the air ducts in the cylinder. 4/2-way and 5/2-way valves are used as the control unit.

If the cylinder is to be moved to an intermediate position (e.g. lifting, holding or lowering), it is necessary to use a 5/3-way valve.

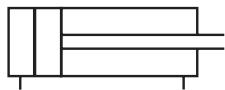

Circuit symbol of double-acting cylinder

### 3.3.3. Actuators for pneumatic process valves

The term "process valves" refers to pneumatically operated, continuous-action valves (control valves) or pilot valves (on/off valves).

The following process valves are used:

- Angle-seat valves, globe valves and diaphragm valves
- Butterfly valves and ball valves.

In regards to the scope of application, the greatest significance is attached to seat valves.

Linear actuators with short strokes and high actuating forces are required for seat valves and diaphragm valves. Special-purpose piston and diaphragm actuators are used for this. They may be single-acting (force of compression against spring force) or double-acting (force of compression for forward movement and return movement; without spring).

Rotary actuators with angles between 0 and at least 90° are required for actuating butterfly valves and ball valves. This rotary movement is primarily produced from a linear movement, e.g. via rack-and-gearwheel coupling, in pneumatic swivel actuators, and in rotary actuators.

The dependence of the pilot pressure which acts on the actuator (on the operating pressure which is obtained in the medium to be controlled) must be noted. This information is provided in tables or diagrams.

#### 3.3.3.1. Piston actuators for on/off process valves/ON/OFF valves

The actuator diameters of a piston actuator lie between 40 and 225 mm. With a maximum pilot pressure of 6 bar, operating pressures up to 10 bar can be switched with the conventional combinations of actuator and valve in the nominal diameter range of 8 to 100 mm.

Pneumatic piston actuators are externally piloted, i.e. they require a control unit/pilot valve for aeration and venting.



Type 2031

**Single-acting piston actuators (the actuator operates against a spring)**

Without pilot pressure, the piston is held in an end position by a spring. The valves to be controlled are closed or open. When the minimum pilot pressure is applied, the piston is moved against the spring force. The valve opens or closes. The air escapes from the spring chamber during this process. It is primarily 3/2-way valves which are used as control units for single-acting piston actuators. These are also referred to as pilot valves.

**Double-acting piston actuators (the actuator operates without a spring)**

The movement in both directions is produced via compressed air acting on the pilot air ports. Without pilot pressure, the piston actuator has no defined position. With an equilibrium of forces on the piston, the piston stops in an intermediate position. In this case, venting is very controlled and in the opposite direction to the application of pressure via the control unit. 4/2-way, 5/2-way and 5/3-way valves or pneumatic control systems are used as the control unit. Diaphragm actuators are also used besides the piston actuators. High actuating forces can be achieved at relatively small strokes with the large-area diaphragms. These diaphragm actuators are extremely advantageous for media to be controlled at a pressure up to 40 bar.

**3.3.3.2. Piston actuators for globe valves or angle-seat valves**

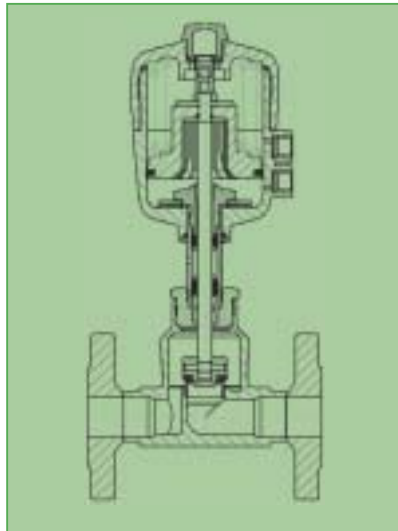

The actuator and valve are coupled by means of a piston rod at whose bottom end the seat disk is attached. The piston rod is guided in a packing gland with stem seals performing a sealing function. The actuators are bolted in the valve. The design of angle-seat valves is very similar to that of globe valves.

Single-acting and double-acting actuators are used for continuous-action process valves. The valve must feature a reproducible (wherever possible, linear) valve characteristic curve. Such a characteristic can be achieved by the use of a specially shaped control cone. The special features of control valves will be described in the Process Valves System Catalog.

**3.3.3.3. Piston actuators for diaphragm valves**

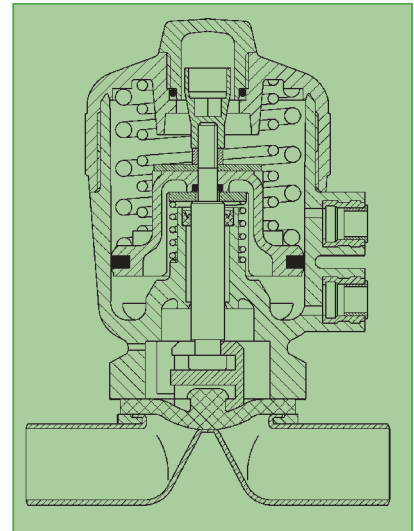

The actuator and valve are coupled by means of a piston rod. The piston rod is connected to the sealing diaphragm and can be detached. This allows the sealing diaphragm to follow the movement of the piston. The valve opens as soon as the sealing diaphragm is raised. Single and double-acting actuators can be used both for pilot valves and for control actuators.

### 3.3.3.4. Diaphragm actuators for globe valves

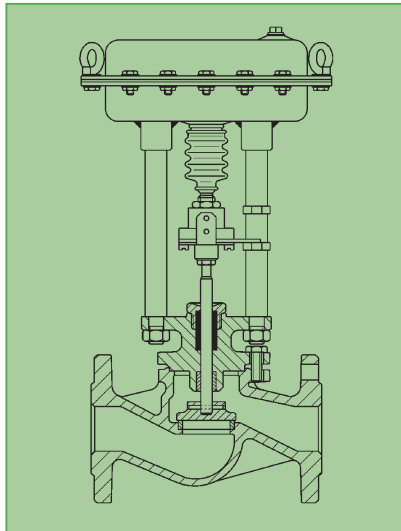

The actuator and valve are coupled by means of a piston rod at whose lower end the seat seal is attached. The piston rod is guided in a packing gland which has a sealing function. The actuator is secured in the valve by means of a threaded nipple.

Single-acting and double-acting actuators are used for continuous-action closed-loop control tasks. In this case, the valve must feature a reproducible (wherever possible, linear) valve characteristic curve. Such a characteristic can be achieved by the use of a special-purpose control cone.

### 3.3.3.5. Rotary actuators for butterfly valves and ball valves

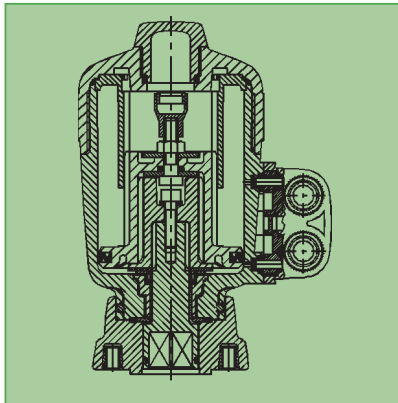

Single-acting or double-acting pneumatic linear piston actuator with internal "rack-and-gearwheel coupling". The "gearwheel" moves a rotary actuator which functions as an interface to the valve and which is standardized in compliance with DIN 3337 and ISO 5211. During the linear movement of the piston resulting from the pressure force or the force of the return spring, the drive shaft is rotated up to max. 90° by the rack-and-gearwheel coupling. This rotary movement is utilized for actuating ball valves, butterfly valves and similar final control elements.

When selecting a pneumatic rotary actuator, particular attention should be paid to the required torque for the final control element.

Single-acting and double-acting actuators are available for using process valves with rotary actuator as continuous-action control valves.

### 3.3.4. Selection criteria for pneumatically operated process valves

- Control function
- Pilot pressure
- Operating pressure
- Torque
- Nominal diameter/Kv-value
- Medium
- Ambient conditions
- Port connections

#### Control functions for process valves

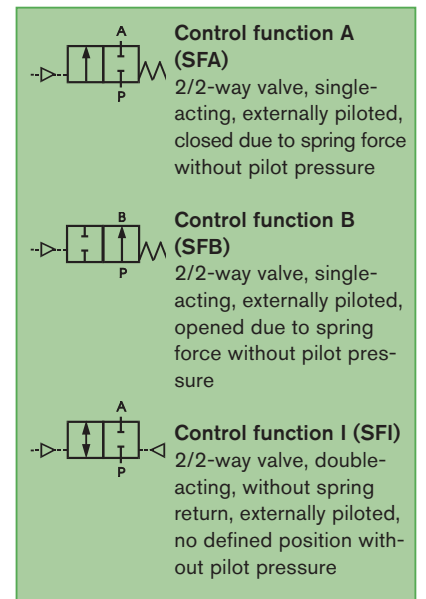

#### Flow direction and water hammer

The flow direction is important when selecting a process valve – particularly in terms of the fluid media to be controlled. If, in the case of control function A, the medium flows through the valve in the closing direction of the valve disk, the closing force of the spring is superimposed on the force due to the medium pressure acting on the area of the valve disk as a result of closing. This closing operation may lead to destruction of the valve, depending on the pressure and size of actuator.



In addition, with such an abrupt closing operation, the flow in the valve drops abruptly and audible closing impacts are produced. Such phenomena can largely be avoided by correct selection of the flow direction.

#### **Pilot pressure and operating pressure**

If the required control function is known, it is possible to determine the combination of nominal diameter and actuator size (combination of DN/AS) using pilot pressure and operating pressure from the table and characteristics provided by the manufacturer. When the nominal diameter is selected, this also defines the  $K_v$  value.

#### **Medium and ambient conditions**

The selection of the materials coming into contact with the medium (body and seal materials) crucially depend on the medium to be controlled. Similar considerations must be made in relation to the resistance of the body materials with regards to the ambient conditions, e.g. temperature, relative humidity, air pollution, etc. The influencing factors in the open air differ substantially from those in covered installations.



**Type 8635**

#### **Port connections**

The port connections result from the requirements made of the system and from the medium. In order to avoid unnecessary flow losses, ensure that the inside diameter of the supply lines is at least the size of the valve nominal diameter when selecting the supply lines.

#### **Torques**

A knowledge of the required torque is necessary in order to couple a final control element to a rotary actuator. When selecting an appropriate rotary actuator, the torque which can be implemented depends on the actuator size and the pilot pressure applied. The corresponding diagrams and selection tables are supplied by the manufacturer.



**Type 2658**

### **3.4. Compressed air “disposal”**

After use, compressed air must be “disposed of” in order to reset control elements or reverse directions of movement, etc. This disposal is generally performed by venting the spent compressed air from a closed volume to the atmosphere. Under certain circumstances, the noise produced during this process must be reduced to (or, better, to lower than) a permitted sound pressure level by the use of mufflers. In order to achieve a good muffling effect, the goal is to ensure the unhindered escape of the compressed air wherever possible, which necessitates as large a muffler filter area as possible. This maximum filter area is, however, generally restricted by the limited installation space.

Lubricated air must be properly de-oiled before being allowed to escape into the atmosphere.

Normally, mufflers consist of plastic, sintered metal, wire fabric or felt.

The following boundary conditions must be noted when selecting a muffler:

- Thread connection size
- Installation space
- Ambient influence
- Max. permitted sound pressure level
- Minimum flow rate
- Contamination tendency.

# 4. Dimensioning

## 4.1. Selection criteria for pneumatic cylinders

- Piston force
- Stroke length
- Piston speed
- Air consumption
- Connection facilities
- Installation
- Ambient conditions.

### Piston force

The piston force is dependent on the air pressure, cylinder diameter and frictional force of the sealing elements. Theoretically possible force ( $A$  = piston area,  $p$  = pressure):

$$F_{th} = A \cdot p$$

### Forces on the single-acting cylinder

( $F_{th}$  less frictional force and return spring force)

$$F_{eff} = A \cdot p - F_R - F_F$$

### Forces on the double-acting cylinder

for the forward stroke ( $A$  = piston area,  $p$  = pressure,  $F_R$  = frictional resistance)

$$F_{eff} = A \cdot p - F_R$$

or

for the return stroke ( $A'$  = piston area less piston rod area)

$$F_{eff} = A' \cdot p - F_R$$

The pressure vs. force diagram supplied by the manufacturer provides the required piston diameter as a function of the required piston force.

### Load of the piston rod, stroke length

The longer the stroke, the greater the mechanical load of the piston rod and guide bearings. In order to avoid buckling of the piston rod, the manufacturer supplied buckling diagram (stroke length as a function of the piston force) must be followed – in particular with a long stroke length.

### Piston speed

The piston speed that can be implemented at a given pressure depends on the counter-force, the air pressure, the line length, the line cross-section between the actuator and final control element, the flow rate through the final control element and the influence of the end of stroke cushioning.

- Standard cylinder speeds are approx. 0.1 to 1.5 m/s.
- One-way flow restrictors in the exhaust duct reduce the speed.
- Quick-exhaust valves in the exhaust duct increase the speed.
- The higher the piston speed and moving mass, the more probable the need for end of stroke cushioning.

### Air consumption (energy costs)

Air consumption in l/min = compression ratio x piston area x stroke x number of strokes/minute.

The air consumption diagram supplies the air consumption  $q_H$  in liters per cm stroke as a function of the piston diameter.

From this, we obtain the air consumption  $q_B$  as follows for singleacting cylinders:

$$q_B = s \cdot n \cdot q_H$$

( $s$  = stroke in cm;  $n$  = number of strokes per minute).

- Double-acting cylinders consume twice as much air as single-acting cylinders.

### Connection facilities, supply lines and cylinder port sizes

Supply lines between control valve and cylinder constitute additional volumes which must be filled and emptied. In order to minimize air consumption and actuation times, the selected lines should be as short as possible.

In order to avoid unnecessary flow losses, the nominal diameter of the supply line must be at least equal to or greater than the cylinder port size. In the case of direct venting into the atmosphere, the permitted sound pressure levels must be taken into consideration. The use of mufflers frequently enables an adequate reduction in the sound pressure level to be achieved. However, mufflers also constitute a flow resistance and thus delay venting.

### Installation and ambient conditions

A cylinder must be installed in compliance with the working task and using the related installation elements. The ambient conditions have a crucial influence on the selection of the materials for the body, piston rod and installation elements of the cylinder. Aluminum, stainless steel and various plastics are mainly used as body materials.

## 4.2.

### Pilot valves for pneumatic actuators

The term “control unit for pneumatic actuators” refers to a function unit with converter function which is able to issue corresponding pneumatic signals for controlling an actuator and which is controlled with primarily low-energy, electrical, mechanical or pneumatic signals. These control units have primarily electrically (magnetically), pneumatically or mechanically operated multi-way valves for switching compressed air.

These pneumatic valves may be differentiated as follows based on the booster’s operating principle and mode of operation:

- spool valves and
- seat valves.

Further differentiating features result from the pilot system’s operating principle:

- pivoted armature
- plunger-type valves
- rocker valves.

Depending on the construction type and rating class, multi-way valves are used to control single and double-acting cylinders, piston and other pneumatic actuators. These include 3/2-way, 4/2-way, 5/2-way and 5/3-way spool valves or seat valves. In the case of multi-way valves, these generally comprise pneumatically operated spool valves or seat valves with a 3/2-way pilot. The table below compares the special features of spool valves and seat valves.

Comparison of seat valves and spool valves

Seat valves	Spool valves
High, pressure-dependent actuating force, pressure differential required across the pilot valve	Low, pressure-independent actuating force since mode of operation is relieved
Low-wear mode of operation, long service life	Non-overlapping mode of operation, i.e. no “short” when switching over
Non-friction seal, self-readjusting dynamically and hardly stressed	Great dynamic stressing of the sealing sliding faces
No stick-slip effect (static friction)	Possible stick-slip effect after long downtimes
Limited flow rates	Higher flow rates
Impulse design is possible	Impulse design can be implemented well
Shorter actuating travels and lower moving masses, i.e. shorter response times	Longer actuating travels and higher moving masses, i.e. longer response times
Tight shut-off over the entire service life	Increasing leakage due to wear

#### 4.2.1. Spool valves

On a spool valve, the individual ports are interconnected or mutually separated, depending on the switch position of the spool unit (switching element), which can be adjusted by sliding. The movement is predominantly axial; it can also be radial or comprise a combination of axial and radial (CETOP RP 100). Spool valves operate fully relieved, i.e. very low forces suffice for switching. This also means that they are able to cope well with higher flow rates or pressures. Switchover between the circuit states is non-overlapping (i.e. switchover without “shorting”) with relatively long travels.

With respect to the cylinder, the spool is sealed by a precise-fit design (metal on metal) or with seal rings (O-rings

on metal). In both cases, there are wear phenomena, i.e. spool valves are never entirely leak-proof. There is always leakage, which increases as the valve becomes older.

On the spool valve, the compressed air controlled by the actuator element moves the spool to the operating position and return elements (mechanical springs or pneumatic springs) return the spool to the original initial position. Impulse valves and 5/3-way valves feature two actuator elements/pilot valves. They have no return element. It is predominantly the 3/2-way pilot solenoid valve which is used as the actuator element for spool valves. In addition, manual actuation via hand lever and finger lever in machines – primarily as an Emergency-Stop function – is of major significance.

Spool valves are available with connection thread for direct installation or in flange design for mounting on manifolds or for mounting directly on actuators.

Spool valves of narrow design are suitable for block assembly. In this case, several valves may be arranged in a space-saving manner on manifolds or valve blocks with fieldbus interface.

Venting ports 3 and 5 may be optionally equipped with restrictor valves in order to e.g. set the return speed of cylinders.

Mufflers can be connected to reduce below venting noise.

The section drawing illustrates a Type 0450 5/2-way spool solenoid valve by way of example.

#### Type 0450 as an example of a servo-assisted 5/2-way spool valve

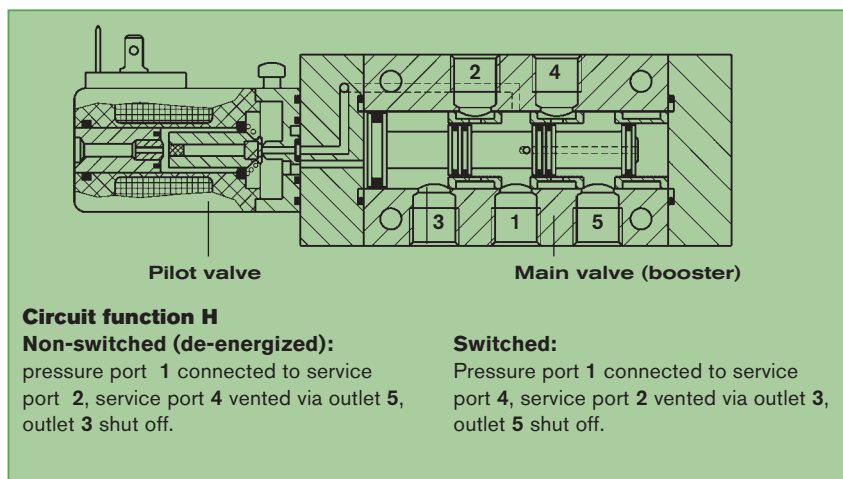

#### 4.2.2. Seat valves

On a seat valve, the ports are connected or disconnected by lowering or lifting a sealing element (e.g. servo-piston). These seals are hermetically tight and self-readjusting, they operate without friction (no stick-slip effect) and are rarely subject to any dynamic stress. Seat valves are very tight over their entire service life. The switching travels are small. The actuating forces are pressure-dependent and relatively high; a pressure differential across the pilot valve is required for switching. The 4/2-way and 5/2-way seat valves in the following examples operate with two servo-pistons. These servo-pistons are forced in opposite directions to the outside by the applied pressure when the pilot valve is not actuated. Ports 1 → 4 and 2 → 3 (5) are thus released. After switching the pilot valve, the pressure is applied to the outer faces of the servo-pistons and the pistons move to the inside. This shuts off the previous port connections and ducts 1 → 2 and 4 → 5 (3) are released.

It is primarily the 3/2-way solenoid valve that is used as the pilot valve. Examples of this are illustrated on pages 24/25 (Type 6012 and Type 6106).

Multi-way seat valves are available with connection thread for direct installation or in flange design for mounting on manifolds or for mounting directly on actuators. Seat valves of narrow design are – similar to spool valves – well-suited for block assembly. Several valves may be arranged in a space-saving manner on manifolds or valve blocks with fieldbus interface. Venting ports 3 and 5 may be optionally restricted in order to e.g. regulate the return speed of pistons in cylinders. Mufflers can be connected to reduce venting noise.

Types 5413 and 6519 are illustrated in the following section drawings, as an example of 4/2-way and 5/2-way seat valves.

Type 5413 as an example of a servo-assisted 4/2-way seat valve

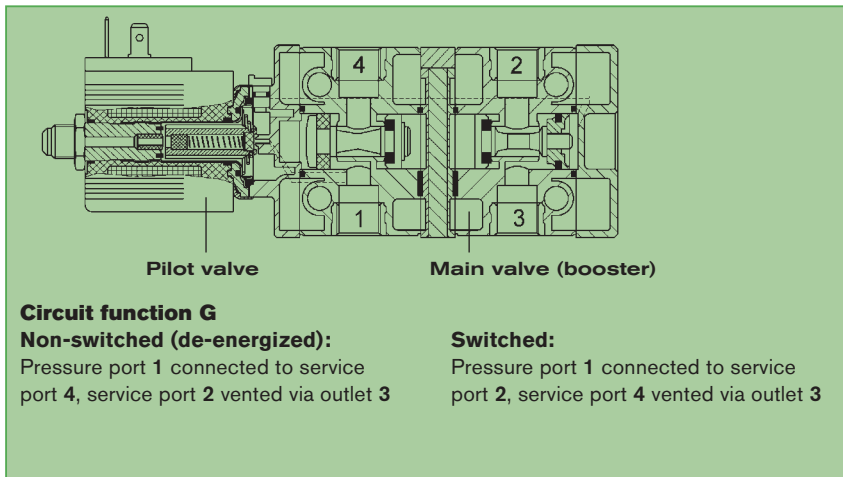

Type 6519 as an example of a servo-assisted 5/2-way seat valve

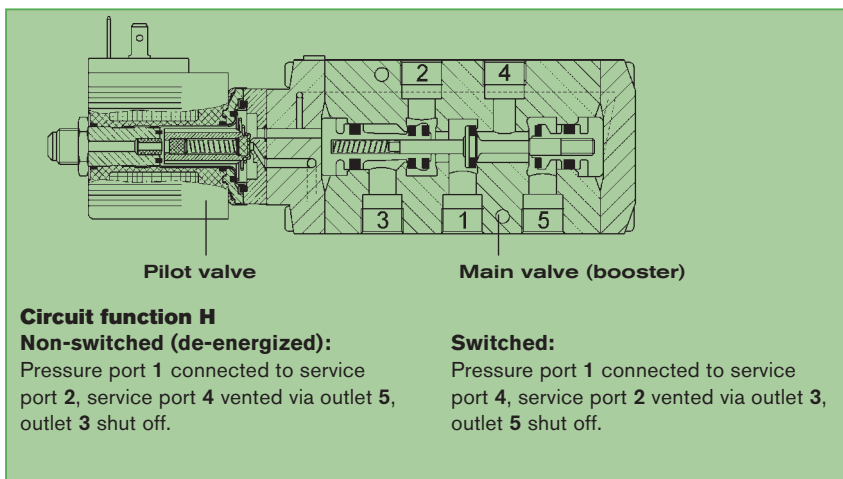



**Type 6011 with flange as an example of a direct-acting 2/2-way plunger-type seat valve**

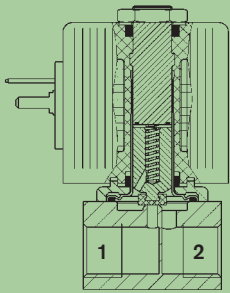

Valve for shutting off and opening a line.  
2 ports, 2 switch positions,  
1 seal.  
Actuation by pulling plunger upwards.

**Circuit function A**  
**Non-switched (de-energized):**  
Pressure port 1 to 2 shut off.

**Switched:**  
Pressure port 1 connected (to) 2 (passage).

Designed as threaded valve or flanged valve.

**Type 6012 with threaded ports as an example of a direct-acting 3/2-way plunger-type seat valve**

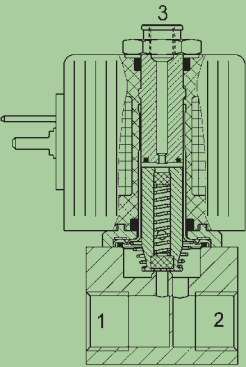

Pilot valve for single-acting actuators.  
Pilot valve for spool valves and seat valves.  
3 ports, 2 switch positions, 2 seals.  
Actuation by pulling plunger upwards.

**Circuit function C**  
**Non-switched (de-energized):**  
Pressure port 1 shut off,  
service port 2 relieved via outlet 3

**Switched:**  
Pressure port 1 connected to outlet 2,  
outlet 3 shut off (plunger in upper position  
closes venting bore 3).

**Type 6106 with flange as an example of a direct-acting 3/2-way rocker valve**

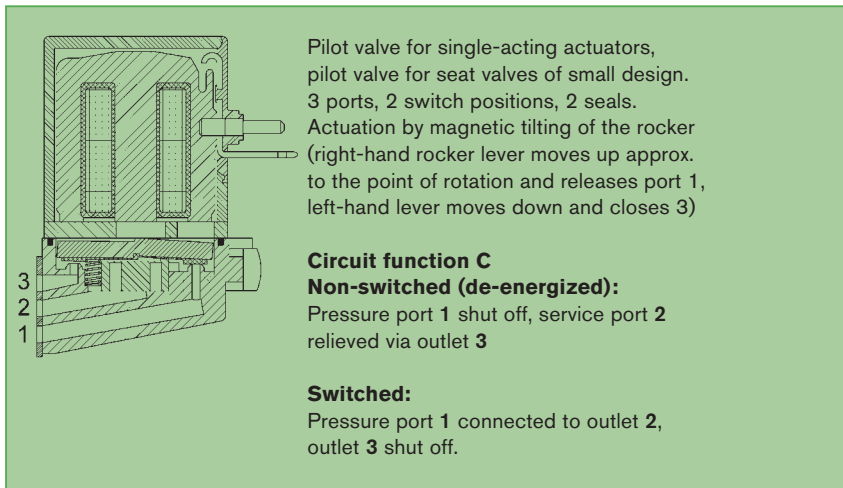

An AC solenoid features a higher pick-up force than a comparable DC solenoid system at the same stroke values. The current consumption of an AC solenoid is determined by the inductance. As the stroke increases, the inductive resistance decreases, thus causing increasing power consumption. This means that a high electric current flows at the switch-on instant. AC solenoids consume far more power at the switch-on instant – at maximum air gap – than they do with the armature picked up.

**Operating voltages**

All electrically operated control valves are primarily available for operating voltages of 24 V DC and 24, 110 and 230 V, 50 Hz, conventionally used in the various industries and sectors. Conversion between the operating voltages is easily achieved by replacing the push-over coil. The solenoid coils consist of an iron core with a moving armature and a coil made of copper wire. The armature seals the valve seat by means of a mechanical spring with a relatively large air gap. After the coil current is switched on, the force produced by the coil solenoid acts on the armature (against the spring force) and pulls the armature into the iron core. The air gap is reduced and, ultimately, reaches zero. As the air gap between armature and iron core becomes smaller, the magnetic force increases.

The design of the solenoid coil must enable the magnetic force to reliably switch the armature against the medium pressure and allow leak-free sealing of the flow direction to be shut off.

On the DC solenoid, the current consumption depends only on the active resistance (ohmic resistance) of the winding. After switch-on, the current rises relatively slowly until it reaches the constant holding current. The armature forces in DC solenoids are below those of AC solenoids with the same overall size, i.e. they are able to switch only lower pressures than AC solenoids with the same nominal diameters. Nevertheless, DC solenoids on valves are important, since a number of control devices (e.g. PLCs) emit DC signals which can be used directly for control. One other area of application relates to battery-operated valves, which can be used if there is no mains power supply, or if mains power would require very complex systems.

### 4.2.3. Circuit functions (WW) and possible applications of multi-way solenoid valves

WW	Circuit symbol	Circuit function	Possible application
A		2/2-way solenoid valve, direct-acting; normally closed; switching without pressure differential	Opening, closing of compressed air lines
A		2/2-way solenoid valve, servo-assisted; normally closed; pressure differential required across valve	Opening, closing of compressed air lines
C		3/2-way solenoid valve, direct-acting; service port 2 normally vented via outlet 3; switching without pressure differential	Pilot valve for single-acting final control elements (low air capacity)
C		3/2-way solenoid valve, servo-assisted; service port 2 normally vented via outlet 3	Pilot valve for single-acting final control elements (high air capacity)
D		3/2-way solenoid valve, direct-acting; service port 2 normally pressurized; switching without pressure differential	Pilot valve for single-acting final control elements (no air capacity)
D		3/2-way solenoid valve, servo-assisted; service port 2 normally pressurized; pressure differential required across valve	Pilot valve for single-acting final control elements (high air capacity)
G		4/2-way solenoid valve, servo-assisted; service port 2 normally pressurized and service port 4 normally vented via outlet 3	Pilot valve for double-acting final control elements; 2 and 4 are always vented via 3
H		5/2-way solenoid valve, servo-assisted; service port 2 normally pressurized and service port 4 normally vented via outlet 5	Pilot valve for double-acting final control elements; venting 2 via 3 and 4 via 5
L		5/3-way solenoid valve, servo-assisted; Position 1: pressure on 2; 4 vented Position 2 (center): everything shut off Position 3: pressure on 4; 2 vented	Pilot valve for double-acting final control elements; lifting, holding and lowering
N		5/3-way solenoid valve, servo-assisted; Position 1: pressure on 2; 4 vented Position 2 (center): 2 and 4 vented Position 3: pressure on 4; 2 vented	Pilot valve for double-acting final control elements; 2 and 4 vented in center position

#### Symbols for the actuating elements on the valve



#### 4.2.4. Selection criteria for multi-way valves

- Final control element, single or double-acting
- Circuit function of control valve
- Flow rate/nominal diameter
- Tube length
- Pilot pressure
- Switching speed
- Operating voltage
- Installation method and location
- Port connections
- Ambient conditions

#### Actuators, circuit function

The required circuit function for the pilot valve results from the actuator's mode of operation (single or double-acting). The options are shown in the table, along with the circuit functions for multi-way valves. Correct dimensioning of the pilot valve, allowing for the supply line, is very important.

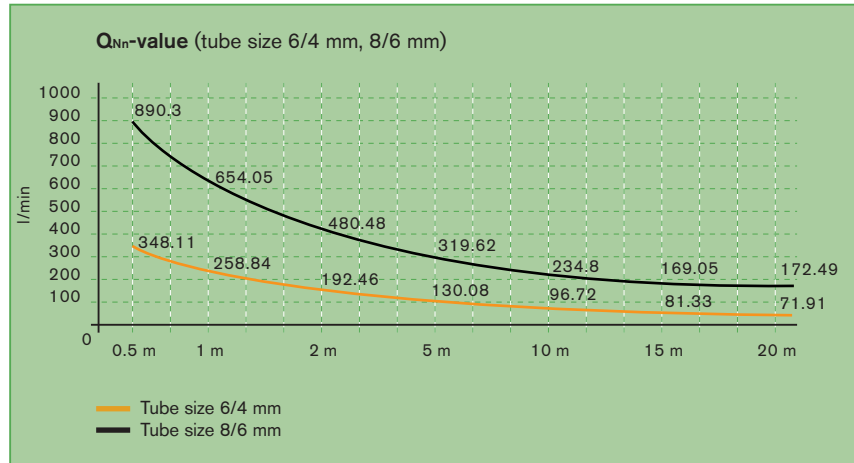

#### Selection of pilot valves (multi-way valves), allowing for the air capacity

The pilot valve has the task of filling or venting, via a supply line, a volume in the actuator within a specific time. The shorter the response time of the actuator, the higher the air capacity of the pilot valve must be. A tube represents an additional flow resistance and a disadvantageous volume. Thus, shortening the tube length reduces the volume to be filled and allows usage of "smaller" control valves. Practice indicates that the flow rate has dropped to 50 % after an approx. 3 – 4 m tube length and has dropped by an additional 20 – 30 % after a further approx. 10 m (also see diagram). Consequently, the losses must also be taken into account when selecting the valves and when dimensioning the tubes.

In addition, it must be ensured that lines are routed as straight as possible, with no kinks, pinching points or elbows since such tube configurations impair the flow conditions, i.e. increase the flow losses in the tube. The diagram also clearly shows that higher flow rates are achieved by increasing the tube's inside diameter from 6/4 mm to 8/6 mm. The diagram shows the effect of the tube lengths (6/4; 8/6 mm) on the air flow rate. Quantitatively similar characteristics also result for tube sizes 10/8 and 12/10 mm. The measurements were conducted with multi-way valves at +20 °C and at an input pressure of 6 bar. The configurators for the valve blocks with fieldbus interface include a calculation tool for calculating flow rates.

#### 4.2.5. Example pilot valve applications for controlling process valves

The multi-way valves, listed with their flow rates in the table below, are well-suited for controlling actuators at switching speeds typical of processes. The required process

valve actuator size is selected on the basis of the operating pressure-pilot pressure diagram or on the basis of the minimum pilot pressure required for process valves in the data sheets. The pilot valve to be selected must be designed for the required pilot pressure range.

Actuator size Ø in [mm]	Tube length [m]	Required flow rate [l/min]	Multi-way valve	Type selection see Table, Page 27
40, 50, 63 80, 100, 125 175, 225	Mounted directly on the valve	approx. 50 approx. 120 approx. 170	<ul style="list-style-type: none"> <li>- Pilot valves mounted directly on the actuator</li> <li>- NAMUR valves, standardized interface for mounting on the actuator</li> </ul>	
40, 50, 63 80, 100, 125 175, 225	Up to 10 m (moderate lengths)	100–150 250–300 300–400	<ul style="list-style-type: none"> <li>- Single valves</li> <li>- Valve blocks</li> <li>- Valve islands with fieldbus interface</li> <li>- AirLINE</li> </ul>	
40, 50, 63 80, 100, 125 175, 225	> 10 m (long lengths)	200–250 500–600 680–850	<ul style="list-style-type: none"> <li>- Single valves</li> <li>- Valve blocks</li> <li>- Valve islands with fieldbus interface</li> <li>- AirLINE</li> </ul>	

If the process valve's switching speed becomes too high with the selected control valve, it is advisable to reduce the pressure or use a restrictor valve in the supply line. Incorrect dimensioning of pilot valves should be avoided. In the case of underdimensioning (nominal diameter / flow rate too low), the process valve switches only very slowly. In the case of overdimensioning (nominal diameter / flow rate too high), there is a possibility of destruction occurring as the result of excessively "hard impacts" in the actuator and valve; there is also the risk of switching errors occurring with specific multi-way valves.

#### 4.2.6 Installation location and method of pilot valves





The pilot valves required for controlling actuators may be fitted at various locations and in different ways. The range extends from direct mounting of the pilot valve on the actuator in the installation to spatially separate installation of valve blocks with fieldbus interface in control cabinets. In such cases, corresponding pneumatic lines must be laid from the control cabinet to the final control element. Among the valves suitable for direct mounting, pilot valves with NAMUR interface should be particularly emphasized. These are valves with a standardized mounting flange pattern.

Example types	Explanation	Application	Special features
<b>Pilot valves</b> 6012P, 6014P	Directional control valve mounted directly on the final control element without additional line; mounting with double nipple, banjo bolt or flange, etc.	Directly controlled for controlling individual valves in the field; local pressure supply required.	Relatively long cables for electrical control; no additional pneumatic lines from valve to final control element; pilot valve must comply with the field conditions.
<b>NAMUR valves</b> 0450 NAMUR 0590 NAMUR 5470 NAMUR 6519 NAMUR	Directional control valve mounted directly on the final control element without additional line; mounting with NAMUR flange.	Directly controlled for controlling individual valves in the field; local pressure supply required.	Relatively long cables for electrical control; no additional pneumatic lines from valve to final control element; pilot valve must comply with the field conditions.
<b>Valve blocks</b> 6012, 6014, 5470 R, 6524, 6525	Valves with common pressure supply buttmounted to form a block by mounting on special multiple manifolds; mounting generally in the field, near the final control elements.	Identical direct control of several final control elements without communication; simple commissioning strategies and favorable maintenance conditions due to block design.	Only one pressure supply to the block required; venting of directional control valves directly into the atmosphere, possibly via muffler or as ducted exhaust via a common exhaust air duct.
<b>Valve islands with fieldbus interface</b> 8640/0450, 8640/5470, 8640/6516,65178640/ 6524,6525 8640/6526, 65278640 EExi	Subassemblies with variable pneumatic and electrical interfaces for performing diverse control tasks, with a modular structure due to a snap-on mechanism; for valves with varying widths per station and air capacities.	Control of a large number of final control elements in installations without and/or with communication (various bus systems); simple use of feedback indicators; control generally via an additional central device (PLC, industrial PC, etc.); easy commissioning and maintenance.	Convenient electropneumatic control units with high packing density; separation of the valve block with fieldbus interface from the field conditions; longer pneumatic lines between valve or via fieldbus technology, e.g. Profibus, Interbus, DeviceNet, CANopen, Selectan, AS-i. Application-specific valve blocks with fieldbus interface can be configured using a configurator.
<b>AirLINE</b> 8644 Phoenix INLINE System  8644 WAGO I/O System 750  8644 Siemens ET 200S  8644 Rockwell Point I/O-System	New type of automation system resulting from integration of electronic, electrical and pneumatic components into one subassembly (in a control cabinet); modular design of electronic, electrical and pneumatic components on corresponding basic modules with little installation effort and expense on standard rails. For valves with differing widths per station and air capacities.	Control of a large number of final control elements in installations without and/or with communication (various bus systems); simple use generally of position indicators; control via the integrated control electronics without and/or with communication, without other control unit.	Integration of central control devices with electronic and electrical modules and valve blocks with fieldbus interface, with electropneumatic pilot valves for the novel AirLINE automation system; control circuitry and electropneumatics are located on a common mounting rail; easy interconnection of electronic modules, electrical supply units and electromagnetic pilot valves via system-specific plug-in contacts; convenient options for system expansion or system reduction; universal fieldbus communication inside to the actuator or sensor and outside to the next control level via Profibus-DP, Interbus, CANopen, DeviceNet, Ethernet or other field bus systems. Application-specific AirLINE stations can be configured with a configurator.









#### 4.2.7. Examples of multi-way valves

Examples of Bürkert types for single pilot valves

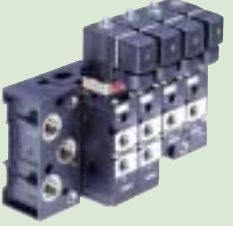
Single pilot valves			
			
Type 6012P	Type 6014P	Type 5470 NAMUR	Type 6519 NAMUR

Examples of Bürkert types for pilot valve units

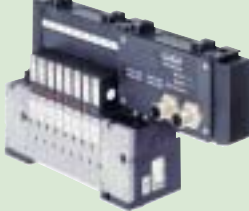
Valve blocks with pilot valves			
			
Type 5420	Type 6012	Type 5470	Type 6518/6519

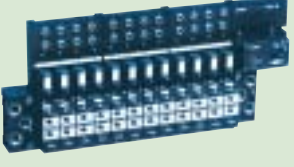
Valve islands with fieldbus interface			
			
Type 8640, 16.5 mm width per station	Type 8640, 11 mm width per station	Type 8640, 19 mm width per station	Type 8640, 33 mm width per station

**AirLINE**



**AirLINE Type 8644, WAGO I/O System 750**



**AirLINE Type 8644, Phoenix INLINE System**

**AirLINE**



**AirLINE Type 8644, Siemens ET 200S**



**AirLINE Type 8644, Rockwell Point I/O-System**



**Valve island with fieldbus interface,  
Type 8640**

## Valve islands with fieldbus interface

Valve islands with fieldbus interface are valve blocks with a common electrical control. Valve blocks are conventionally connected and controlled with single wiring. In the case of a valve island with fieldbus interface, communication is implemented within the system.

Valve islands with fieldbus interface are latched together from individual modules. All interfaces within a series are fully compatible. The most important modules are as follows:

- Basic pneumatic modules for width per station 11, 16.5, 19 and 33 mm with differing numbers of valve positions; maximum number of valves on a valve block with fieldbus interface: 24 (up to 168 valves can be addressed via RIO expansion)
- Valves are screwed on to the basic pneumatic modules from the front.
- Pneumatic connector modules for connection of the compressed air and exhaust air
- Basic electrical modules (power supply, feedback indicator, manual-automatic switch, external de-activation devices, digital outputs, etc.)
- Feedback indicator for digital inputs on the valve block with fieldbus interface, max. 32
- An additional 48 digital inputs or outputs can be integrated via a separate I/O module.
- Conventional electrical control with bus terminal and multi-pin

- Electrical control via fieldbus modules (Profibus, Interbus, DeviceNet, CANopen, Selecan and AS-i)
- Up to 7 valve terminals with fieldbus interface can be controlled with a fieldbus node via RIO expansion (with PROFIBUS).

All module versions are described in full detail on the data sheets or in the configurator for valve blocks with fieldbus interface, Type 8640.

Other special features:

### **Valve replacement in ongoing operation**

#### **1. Integrated check valve in the P-channel**

The valve blocks with fieldbus interface can be optionally equipped with a P shut-off. This P shut-off allows replacement of a valve without having to depressurize the entire valve block with fieldbus interface. With the P shut-off, a mechanism seals, apart from minor residual leakage when the valve is removed, the cross-section of the P port pertaining to the valve. The valves remaining on the valve block can continue to be operated unrestrictedly with the valve removed. When a new valve is fitted, the P shut-off is reopened automatically.

### **Switching errors due to congestion in the exhaust duct**

#### **2. Integrated check valves in the R-channel**

On valve blocks with fieldbus interface, the exhaust air for venting the actuators is generally routed to the outside via central exhaust air lines, where it is relieved via mufflers into the atmosphere in order to reduce the sound pressure level and save on mufflers. In this case, the exhaust air to be relieved is collected in the exhaust air lines. If this exhaust air is not relieved quickly enough into the atmosphere, a pressure which delays closure of the process valves can build up in these lines. More rapid pressure reduction in the exhaust air lines helps to remedy this situation. This can be done with additional or higher volume exhaust air lines, additional supply or exhaust air modules and with quick-exhaust valves. This air congestion in valve blocks with fieldbus interface or in conventional valve blocks can also lead to idle pilot valves passing on the pressure to their outlet, thus causing a process valve to unintentionally open for a short period of time. This may result in major damage to the process. In order to counteract these problems, i.e. to offer a technical solution, check valves may be integrated in the exhaust air ducts in the basic pneumatic modules. This measure precludes the possibility of unintentional switching as a result of air congestion.



**AirLINE, Type 8644**

## **AirLINE Electrical and pneumatic automation system**

### **Distributed periphery**

Innovative I/O systems for ideal solutions in the control cabinet. Such systems are available from a number of manufacturers, e.g.:

Siemens: SIMATIC ET 200S  
Phoenix Contact: INLINE-System  
WAGO: I/O-System 750  
Rockwell: Point I/O-System

More flexible, smaller, faster and less expensive – these are the trends in automation. Distributed periphery means plugging in instead of wiring. The automatic cross-wiring is achieved by an integrated plug connection system.

With their high flexibility, distributed peripherals ensure long-term savings. Wiring and piping are very easy and the fine modular design of the systems allows multi-functional use of the station. One other advantage is the reduction in space required in the control cabinet.

These distributed peripheral systems have one thing in common: input and output system and valve block with fieldbus interface are integrated in a single unit – this is a brief description of AirLINE.

But what does that mean?

This system is the universal interface between the process and installation control. Sensor inputs are scanned via binary and analog input modules and final control elements or complete, distributed control systems, e.g. for flow rate, pressure, temperature, filling level and chemical parameters, are controlled via corresponding binary and analog output modules. Pneumatic outlets with an extremely wide variety of circuit functions and flow rates switch single or double-acting process valves. AirLINE can be set up without tools by means of an extremely simple snap-on mechanism on a standard rail. This enables a flexible, application-oriented configuration.

AirLINE offers the option of integrating the following pneumatic functions in distributed, fieldbus-enabled I/O system platforms:

- 3/2-way, 5/2-way monostable, 5/2-way bistable and 5/3-way functions
- 11 mm width per station, flow rate of up to 300 NI/min
- 16.5 mm width per station, flow rate of up to 700 NI/min
- Various flow rates can be combined in one system
- Pressure range from vacuum to 10 bar
- 64 valves per station.

In addition, other functions are offered to the user:

- Integration of check valves (for a description, see above: Valve blocks with fieldbus interface)
- Integration of P shut-off (for a description, see above: Valve blocks with fieldbus interface)
- Various pressure stages can be implemented in an interlinked system
- Grouped supply and exhaust air
- Valves are accessible from the front
- Option for subsequent on-site expansion
- Intelligent pressure measuring module for processing limit values, threshold values and a great deal more.

Summary of AirLINE system advantages:

- Function-oriented configuration of distributed units
- No cross-wiring
- Clear reduction in control cabinet configuration
- Only one fieldbus interface for the entire functional unit
- Simple configuration and expansion options directly on-site
- Maximum flexibility due to fine modularity
- Space saving in the control cabinet

#### **4.2.8. Selection criteria for pilot valves and pilot valve units**

- Number of actuators to be controlled
- Control signal direct or from a central control unit
- Control without and/or with communication
- Operating voltage
- Minimum pilot air flow rate for the actuator
- Required tube length between pilot valve and actuator
- Mounting method on actuator with single valves
- Valve block with mounting in the field; short tubes
- Valve block with fieldbus interface, with mounting in control room/control cabinet; long tubes.



# 5. Pneumatics in automation engineering

## 5.1. Factory automation

---

The term production automation refers to computer-aided automation of production in all technical and organizational areas of a factory. One special point of emphasis relates to automatic assembly of subassemblies and devices (e.g. vehicle assembly). This primarily requires transport systems, material flow systems, handling systems, robot systems and measuring systems which are connected with computer assistance. In many cases, pneumatically operated actuators are used for this (e.g. cylinders). These systems must smoothly interwork at high speed in the production process.

Important requirements related to production automation are as follows:

- High actuating forces
- High actuating speeds
- Short, moderate and long actuating travels
- High flexibility in workpiece handling
- High clock rates
- Ultra-short response times
- Complex control valve functions
- High-performance and rugged actuators and final control elements (actuators)
- Compact types of construction
- Sophisticated modular concepts.

## 5.2. Process automation

---

Using sensors, process data is determined, processed in controllers or control computers and utilized to intervene in the process via actuating signals and final control elements (actuators). One special point of emphasis pertains to automation of continuous and batch processes as frequently encountered in the chemical industry and process engineering (energetic and material processes). In such cases, pneumatic actuators on process valves are frequently used for switching or controlling material streams. These process valves must be able to be matched easily to the actual technical process conditions.



Important process-automation requirements related to the actuation systems are as follows:

- High availability
- Reliable coping with low and moderate speeds
- Rugged, long-life designs
- Simple pilot valve functions
- Low and moderate air capacities
- Easy information procurement (feedback indicators, position sensors, flow detectors and pressure detectors, etc.)
- Interfaces and connections for bus communication
- Good control properties of the process valves.

## 6. Flow valves, shut-off valves and accessories

The circuit functions of the most important flow valves and shut-off valves are described in the table below in accordance with DIN ISO 1219-1. In daily use, these flow valves and

shut-off valves are jointly interconnected with pilot valves and process valves to form pneumatic installations. Bürkert offers these types of components (see Types 1013 AG, 1013 BC, 1013 BI and 1013 BJ).

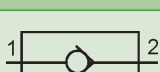
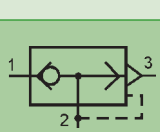
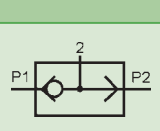
	Adjustable restrictor valve, simple change in flow resistance; pressure-dependent flow rate
	Adjustable flow control valve, use of a pressure differential controller; pressure-independent constant flow rate
	One-way flow restrictor, pressure-dependent restrictor acts in one direction, free flow in opposite direction
	Check valve or shut-off valve, shuts off volume flow in one direction, free flow in other direction (comparable with an electrical diode)
	Quick-exhaust valve, if pressure is applied to inlet 1, the ball blocks off vent 3 and the pressure is routed to the outlet 2; in the case of overpressure at 2 with respect to 1, inlet 1 is shut off (by the ball) with the feedback and 2 is vented directly via 3.
	Shuttle valve or OR-element; inlet P1 or P2, which is pressurized, is connected to 2 and the other inlet is shut off (by the ball); if both inlets are pressurized, the inlet with the lower pressure is shut off and the higher pressure is routed to the outlet.

### 6.1. Restrictor valves and flow control valves



Restrictor valves and flow control valves serve to regulate a flow rate. A distinction is made between restrictor valves which operate pressure-dependently and flow control valves which operate pressure-independently. With the restrictor valve, the volume flow is dependent on the pressure differential across the restrictor. With the flow control valve, a pressure differential controller produces a constant flow. Restrictor valves and flow control valves, in combination with a volume to be filled, form a pneumatic RC network. By varying the flow rate, it is thus possible to influence the filling and emptying speed of a volume (i.e. the time constant).

Flow valves can be used e.g. for the following applications:

- to limit the speed of rotation of compressed air motors
- to reduce the traversing speed of pneumatic linear or rotary actuators
- to set the air flow rate on ejection nozzles
- to act as a resistance in pneumatic timers.

### 6.2. Check valves or shut-off valves

---

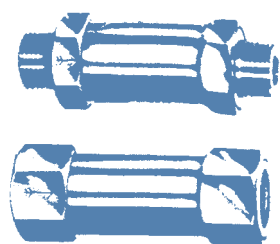

A check valve – also referred to as shut-off valve – shuts off the volume flow in one direction and releases the flow, unhindered, in the opposite direction. In order to obtain a good seal in the shut-off position, check valves are designed with a cone or ball. The shut-off function is generally spring-activated and spring action is further reinforced by the medium pressure on the shut-off element. A check valve can be combined with a flow valve to form a one-way flow restrictor.

### 6.3. Quick-exhaust valves

---



Quick-exhaust valves are selector valves which are opened as a result of the supply line pressure in the direction of the consumption unit and which release the exhaust air port when switching over as the result of the consumption unit pressure. Quick-exhaust valves are primarily used to shorten exhaust-air distances (to avoid congestion in the exhaust air line) and increase the stroke or return stroke speed of pneumatic actuators. Quick-exhaust valves very frequently serve to increase the return speed of pneumatic cylinders and process valves.

### 6.4. Shuttle valves or OR-element

---



Shuttle valves or OR-elements are used wherever a pneumatic actuator is to be controlled optionally from two different pressure sources. The OR-element has two inlets and one outlet. A shut-off element closes the unpressurized inlet, thus preventing reciprocal influencing of the control elements. If both inlets are pressurized, the inlet with the lower pressure is shut off and the higher pressure is routed to the outlet. Besides controlling an actuator comprising two pressure sources, the OR-element can also be used as a locking element for parallel pneumatic circuits.

## 6.5. Accessories

The term “accessories” comprises all elements which have not yet been described and which are required for configuring a pneumatic system.

These include, in particular:

- plastic tubes (Type 1013 AF)
- mufflers (Type 1013 AJ)
- screwed fittings (Type 1013 AA)
- plug-in fittings (Type 1013 AB)
- compression fittings (Type 1013 AT).

## 6.6. Selection criteria for flow valves, shut-off valves and accessories

- Pressure range
- Flow rates
- Body material
- Temperature compatibility
- Type of construction and dimensions
- Mounting options
- Port connections
- Flow direction(s)

The most important criteria for selecting flow valves, shut-off valves and accessories are pressures and flow rates, materials for environmental resistance, port connection sizes, mounting options and tube lengths (see Section 3.5.4.).

In particular, already existing mounting options, such as internal threads, external threads, plug-in fittings, etc., should be used directly for mounting.

### Accessory examples



# 7. Control signals for pilot valves

A pneumatic actuator is controlled by a control unit with pneumatic signals, i.e. the output signals of the control unit. In turn, the control unit receives the control signals from upstream signal-processing devices, such as limit switches, hand levers, timing controls, NC machine controls, PLCs, etc. The controlling signal may be electrical, pneumatic, optical, mechanical or another physical type. Non-pneumatic signals are converted in the control unit to adequate pneumatic signals. Many control units also feature corresponding – generally electronic – devices for processing control signals and conditioning actuating signals. It is also possible to receive and process programming and status signals in control units with corresponding artificial intelligence.

The control unit issues pneumatic actuating signals, predominantly in the following form, for actuating pneumatic actuators:

- Continuous signals
- PWM pulse trains (PWM = pulse width modulation).

Electrical or electronic control signals on which the energy of the signal level:

- is used for directly actuating the pilot valve (two-wire system) or
- needs to be conducted in additional supply lines (special bus interfaces) are mainly used for control of pilot valves for actuating process valves.

Transmission channels are also required for forwarding status signals – e.g. feedback signals on the switch position of process valves. These may be single lines for analog signals or bus lines for discrete (coded) signals. The supply of control signals and forwarding of status signals are also handled analogous to the control options of actuators with pilot valves. The range in this case extends from direct single control of a valve via a single cable to block control or group control by means of a bunched cable with multi-pin interfaces and up to cable-saving bus communication between installation sections and central controls.

A distinction is made between direct control and communication by networking in relation to control of a pilot valve with signals.

## Direct control

- Direct control of individual pilot valves mounted on process valves
- Direct control of pilot valve groups on valve blocks via direct wiring between pilot valve(s) and signal generator(s) digital outlet(s).
- Direct control of pilot valve groups on valve blocks with fieldbus interface via bunched cables with multi-pin interface on the valve block without communication (simple connection of the individual valves via prepared plug units); the multi-pin interfaces may also be used simultaneously for forwarding status signals.

## Fieldbus technology

The use of fieldbus systems enables a significant reduction in the installation and maintenance costs associated with a measurement, control and regulation system.

However, before using the system for the first time, one should carefully review which bus system promises optimum benefit for your own application. A comparison of purely technical data generally does not suffice to achieve a secure investment. The availability of field-tested devices and market trends are but two further criteria which need to be assessed.

### Why fieldbus technology?

Conventionally, sensors and actuators are connected to a control or evaluation unit by means of an analog 4 – 20 mA signal. This technology requires one 2-wire cable for each connection between sensor or actuator and control. In addition, each sensor and actuator must be provided with an input or output circuit in the control. The situation if a fieldbus system is used is entirely different: all devices are connected to a bus cable. An interface board is used in place of the input/output circuits. This saves on I/O cards, reduces the space required in the control cabinet and cuts wiring costs on a sustained basis. On conventional systems, information can be transmitted in one direction, i.e. only from the sensor to the control or from the control to the actuator, only to a very restricted extent. In contrast, on a fieldbus system, information can be bi-directionally exchanged via the digital bus. In addition to the actual process data, e.g. measured values and control parameters, it is also possible to transmit parameters such as measuring range, filter characteristics, maintenance or fault signals, etc. The advantages resulting from this are obvious. Commissioning and maintenance are simplified and flexibility of the system is enhanced. In comparison to conventional solutions, this also allows general cost advantages.



- Bus communication between the electronic control units on the valve blocks with fieldbus interface and the central control unit; bus connections to pilot valves and sensors with all fieldbus systems typically used in processes (PROFIBUS DP, InterBus, Device Net, CANopen, SELECAN and AS-Interface, Ethernet, etc.)
- Integration of central control devices with electronic and electrical modules, in addition to valve blocks with fieldbus interface and electropneumatic pilot valves, to form the new AirLINE automation system; control circuitry and electropneumatics are located on a common mounting rail; electronic modules, electrical supply units and solenoid-operated pilot valves are very simply interconnected via system-specific plug-in contacts; convenient options for system expansion or reduction; universal fieldbus communication inside to the actuator or sensor and outside to the next control level via PROFIBUS DP, Interbus, CANopen, DeviceNet, Ethernet or other fieldbus systems.

Please refer to Bürkert brochure “Fieldbus Technology” for further information on bus communication. The brochure provides useful information for practical applications as well as information on:

- the requirements, benefits and costs of fieldbus technology
- special communication systems such as Profibus, Interbus, AS-Interface, Foundation Fieldbus and HART protocol for bus-addressed field units
- fieldbus technology in hazardous areas
- topology considerations
- bus communication in process control systems
- the comparison of fieldbus systems typically used in processes
- Bürkert communication-enabled field units.



# 8. Pneumatics search trees

## 8.1. Single valves (multi-way valves)

	Circuit function			Actuation			Body material		Nominal diameter [mm]	Pressure range [bar]	Flow rate [l/min]	Port connections										Type No.			
	3/2-way valve	4/2-way	5/3-way	mechanical	pneumatic	servo-assisted	direct-acting	Aluminium				Plastic	Flange	8 mm plug-in coupling	6 mm plug-in coupling	4 mm plug-in coupling	G 1/2 threaded port	G 3/8 threaded port	G 1/4 threaded port	G 1/8 threaded port	M5 threaded port		SL 6/4	Ex approval, optional	Fieldbus-enabled
<b>Piston spool valves</b>	▪	▪	▪				▪		13	1-10	1,600											▪	<b>0590</b>		
	▪	▪	▪				▪		13	1-10	1,600											▪	<b>0590 EExi</b>		
	▪	▪	▪				▪		13	1-10	1,600											▪	<b>0590 EExm</b>		
	▪	▪	▪	▪				▪		4-6	0-16	Up to 720											▪	<b>0450 Mech</b>	
	▪	▪	▪		▪			▪		4-14	0-12	Up to 3,300											▪	<b>0450 Thread</b>	
<b>Pneumatic valves</b>	▪							▪	6	1-10	900											▪	<b>5411</b>		
	▪	▪						▪	6	1-10	900												▪	<b>5413</b>	
	▪							▪	3	2.5-10	200	▪								▪			▪	<b>5420</b>	
	▪							▪	3	2.5-10	200	▪								▪		▪		<b>5420 EEx</b>	
	▪							▪	8	2-8	1,300	▪												▪	<b>6518</b>
	▪							▪	8	2-8	1,300	▪												▪	<b>6518 EEx</b>
	▪							▪	8-9	2-8	1,300	▪												▪	<b>6518 EExi</b>
	▪	▪						▪	▪	8-9	2-10	1,300	▪											▪	<b>6519</b>
	▪	▪						▪	▪	8-9	2-10	1,300	▪											▪	<b>6519 EEx</b>
	▪	▪						▪	▪	8-9	2-10	1,300	▪											▪	<b>6519 EExi</b>
<b>Rocker solenoid valves</b>	▪							▪	0.6	0-7	Up to 8.5	▪											▪	<b>6104</b>	
	▪							▪	0.9-1.2	0-10	Up to 47	▪											▪	<b>6106</b>	
	▪							▪	2.5	2.5-7	130	▪											▪	<b>6510</b>	
	▪	▪						▪	2.5	2.5-7	130	▪											▪	<b>6511</b>	
	▪							▪	8	2-8	1,300	▪												▪	<b>6516</b>
	▪							▪	8	2-8	1,300	▪												▪	<b>6516 EExi</b>
	▪							▪	8	2-8	1,300	▪												▪	<b>6517</b>
	▪							▪	8	2-8	1,300	▪												▪	<b>6517 EExi</b>
	▪							▪	4	$V_{acu}^{-10}$	300	▪												▪	<b>6524</b>
	▪	▪						▪	4	1-10	300	▪												▪	<b>6525</b>
	▪							▪	6	$V_{acu}^{-10}$	700	▪												▪	<b>6526</b>
	▪							▪	6	1-10	700	▪												▪	<b>6527</b>
	▪	▪						▪	4	2-10	300		▪											▪	<b>5470 E</b>
▪	▪						▪	4	2-10	300		▪										▪	▪	<b>5470 EExi</b>	

## 8.2.

### Valves for direct mounting on the actuator

#### 8.2.1. NAMUR valves

	Circuit function			Func-tion	Body material				Nominal diameter [mm]	Pressure range [bar]	Flow rate [l/min]			Type No.
	3/2-way	4/2-way, 5/2-way	5/3-way		servo-assisted	direct-acting	Aluminum	Plastic				Brass	Stainless steel	
<b>Pneumatic valves</b>	▪	▪	▪	▪	▪				13	1–10	1,600		▪	<b>0590</b>
	▪	▪	▪	▪	▪				13	1–10	1,600	▪		<b>0590 EExi</b>
	▪	▪	▪	▪	▪				13	1–10	1,600	▪		<b>0590 EExm</b>
		▪		▪		▪			6	2–8	750			<b>0450 Flansch</b>
	▪	▪		▪			▪		6	2–8	900		▪	<b>6519 NAMUR</b>
	▪	▪		▪			▪		6	2–8	900	▪		<b>6519 NAMUR Ex</b>
	▪	▪		▪			▪		6	2–8	900	▪		<b>6519 NAMUR EExi</b>
<b>Rocker solenoid valves</b>	▪	▪		▪		▪			4	2–10	300	▪	▪	<b>5470 NAMUR</b>
	▪	▪		▪		▪			4	2–10	300	▪		<b>5470 NAMUR EExi</b>
	▪	▪		▪		▪			6	2–8	900	▪	▪	<b>6517 NAMUR</b>

### 8.2.2. Pilot valves

	Circuit function			Function		Body material			Nominal diameter [mm]	Pressure range [bar]	Flow rate [l/min]	Port connections					Type No.	
	3/2-way	4/2-way, 5/2-way	5/3-way	electrical pilot	electrically direct-acting	Aluminum	Plastic	Brass				Stainless steel	G 1/4 threaded port	G 1/8 threaded port	SL 6/4	Ex approval, optional		Fieldbus-enabled
<b>Miniature solenoid valve</b>	▪				▪		▪	▪		1.2–1.6	0–10	48	▪	▪	▪		▪	<b>6012</b> <b>6012 P</b>
<b>Small-size solenoid valve</b>	▪				▪		▪	▪		1.5–2.5	0–10	up to 120	▪	▪			▪	<b>6014</b> <b>6014 P</b>

### 8.3.

## Valve blocks

Circuit function					Body material		Pressure range	Flow rate	Port connections						Width per station					Type No.			
3/2-way	4/2-way, 5/2-way monostable	5/2-way bistable	5/3-way		Polyamide (PA)	Aluminum	[bar]	[l/min]	8 mm plug-in coupling	6 mm plug-in coupling	4 mm plug-in coupling	M5 threaded port	G 1/8 threaded port	G 1/4 threaded port	11 mm	16.5 mm	19 mm	33 mm	Ex approval	Number of valves ≤ 24	Number of valves > 24		
▪	▪				▪		V <sub>accu</sub> <sup>-10</sup>	300		▪	▪	▪			▪				▪		▪		6524/25
	▪				▪		2.5–10	200					▪						▪		▪		5420
	▪				▪		2.5–10	200					▪						▪		▪		5420 EEx
▪	▪				▪		2–10	300		▪								▪			▪		5470 M
▪	▪				▪		2–10	300											▪			▪	8640 EExi
▪	▪	▪	▪		▪		2–10	up to 1,580											▪			▪	0450
▪	▪	▪	▪		▪		2–8	750											▪		▪		8640 EExi
▪	▪				▪		2–8	1,300	▪										▪			▪	6516/17
▪	▪				▪		2–8	1,300	▪										▪		▪		6516/17 EExi
▪	▪	▪	▪		▪		2–8	1,300	▪										▪			▪	6518/19
▪	▪				▪		2–8	1,300	▪										▪		▪		6518/19 EExi
▪	▪				▪		V <sub>accu</sub> <sup>-10</sup>	750	▪							▪			▪			▪	6526/27

### 8.4.

### AirLINE/valve islands with fieldbus interface

Indi- cation	Function					Electrical control							Width per station				Flow rate				Type			
	Valves <= 24	Valves > 24	3/2-way	4/2-way	5/2-way monostable	5/2-way bistable	5/3-way	Bus terminal	Multi-pin	PROFIBUS DP	INTERBUS	CANopen	DeviceNet	Ethernet	ASI	11 mm	16.5 mm	19 mm	33 mm	< 130 l/min		< 300 l/min	< 700 l/min	< 300 and 700 l/min
•			•		•		•	•	•	•	•	•		•	•					•				8640/ 6524 6525
•			•		•		•	•	•	•	•	•		•		•					•	•		8640/ 6526 6527
•			•	•			•	•	•	•	•	•		•			•				•			8640/ 5470
•			•		•	•	•	•	•	•	•	•		•			•					•		8640/ 0450
•			•		•		•	•	•	•	•	•		•				•					•	8640/ 6516 6517
•	•		•		•	•				•	•	•	•		•						•			AirLINE 8644 Phoenix INLINE System 11 mm
•	32		•		•	•				•	•	•	•		•							•		16.5 mm
•	•	•	•		•	•				•	•	•	•		•						•			AirLINE 8644 Wago, I/O System 750 11 mm
•	32		•		•	•				•	•	•	•		•							•		16.5 mm
•	•	•	•		•	•				•	•	•	•		•						•			AirLINE 8644 Siemens, ET 200S 11 mm
•	32		•		•	•				•	•	•	•		•							•		16.5 mm
•	•	•	•		•	•				•	•	•	•		•						•			AirLINE 8644 Rockwell, Point I/O System 11 mm
•	32		•		•	•				•	•	•	•		•							•		16.5 mm





## 8.5. Cylinders

	Function		Body material		Pressure range [bar]	Piston diameter [mm]	Stroke [mm]							Type No.			
	single-acting	double-acting	Aluminum	Plastic				Stainless steel	End of stroke cushioning	Inductive limit switches*	Non-rotating	ISO 6432 (Cetop)	ISO 6431		ISO 6431 VDMA 24562	DIN 6432	Mounting elements*
Plastic cylinder with VA piston rod	▪			▪		1–10	12–25	25–150	▪	▪		▪				▪	0044 0045
Plastic cylinder with VA piston rod		▪		▪		1–10	32–50	50–200	▪	▪			▪			▪	0044 0045
Pneumatic cylinder			▪			1–10	32–125	25–250	▪	▪						▪	0047
Pneumatic cylinder				▪		1–10	8–25	10–200	▪	▪						▪	0049/0050
Pneumatic cylinder					▪	1–10	8–25	10–50		▪						▪	0049/0050

Inductive limit switches and mounting elements, see Accessories

## 8.6. Service units

	Body material		Input pressure range [bar]	Output pressure [bar]	Flow rate [l/min]	Filter-water separator	Diaphragm pressure control valve	Fog lubricator	Pressure gauge	Port connection					Type No.	
	Metal	Plastic								G 1/8	G 1/4	G 3/8	G 1/2	G 3/4		G 1
Service units	▪	▪	0–16	0.5–8	up to 5,000	▪	▪	▪	▪	▪	▪	▪	▪	▪	▪	1032 AL

## 8.7.

### Flow valves and shut-off valves

	Body material			Pressure range [bar]	Flow rate [l/min]	Port connection							Type No.				
	Aluminum	Plastic	Stainless steel			12 mm plug-in coupling	10 mm plug-in coupling	8 mm plug-in coupling	6 mm plug-in coupling	4 mm plug-in coupling	G 1 threaded port	G 1/2 threaded port		G 3/8 threaded port	G 1/4 threaded port	G 1/8 threaded port	M5 threaded port
<b>Screw-in regulation valves</b>		▪		up to 18		▪	▪	▪	▪	▪		▪	▪	▪	▪	▪	<b>1013 AG</b>
Exhaust restrictor		▪		up to 18		▪	▪	▪	▪	▪		▪	▪	▪	▪	▪	<b>1013 AG</b>
Supply restrictor		▪		up to 18		▪	▪	▪	▪	▪		▪	▪	▪	▪	▪	<b>1013 AG</b>
One-way flow restrictor		▪		up to 18		▪	▪	▪	▪	▪		▪	▪	▪	▪	▪	<b>1013 AG</b>
Restrictor valve		▪		up to 18		▪	▪	▪	▪	▪		▪	▪	▪	▪	▪	<b>1013 AG</b>
Check valve		▪		up to 18		▪	▪	▪	▪	▪		▪	▪	▪	▪	▪	<b>1013 AG</b>
<b>Restrictors and restrictor mufflers</b>												▪	▪	▪	▪	▪	<b>1013 BC</b>
<b>Shuttle valve</b>	▪			0.1-10	200										▪		<b>1013 BI</b>
<b>Quick-exhaust valve</b>			▪	0.5-12	up to 7,800								▪	▪	▪		<b>1013 BJ</b>

## 8.8.

### Accessories

	Body material			Plastic tubes	Port connection	Dia- meter		Type No.
	Brass, nickel-plated	Stainless steel	POM					
<b>Plug-in fittings</b>	▪		▪		G1/8-G1/2			<b>1013 AB</b>
<b>Screwed fittings</b>	▪			▪	G1/8-G3/4			<b>1013 AA</b>
<b>Plastic tubes</b>				▪				<b>1013 AF</b>
<b>Mufflers</b>					M5-G1			<b>1013 AJ</b>
<b>Compression fittings</b>	▪	▪			G1/8-G1 1/2	4-42		<b>1013 AT</b>
<b>Mounting elements for cylinders</b>						32-125 8-25		<b>1014 AD</b>
<b>Pressure switches</b>							▪	<b>1045 AE</b>
<b>Solenoid-sensitive sensors</b>							▪	<b>1071</b>

## 9. Glossary

### Current consumption of AC solenoids

An AC solenoid features a higher pick-up force than a comparable DC solenoid at the same stroke values. The current consumption of an AC solenoid is determined by the inductance. As the stroke increases, the inductive resistance decreases, thus causing increasing power consumption. This means that a high electric current flows at the switch-on instant. AC solenoids consume far more power at the switch-on instant – at maximum air gap – than they do with the armature picked up.

### Current consumption of DC solenoids

On the DC solenoid, the current consumption depends only on the active resistance (ohmic resistance) of the winding. After switch-on, the current rises relatively slowly until it reaches the constant holding current. The armature forces in DC solenoids are below tube of AC solenoids with the same coil size (number of windings and wire diameter), i.e. they are able to switch only lower media pressures than AC solenoids with the same nominal diameters. Nevertheless, DC solenoids are important as valve actuators, since a number of control devices (e.g. PLCs) emit DC signals which can be used directly for control. One other area of application relates to battery-operated valves, which can be used if there is no mains power supply or special power supply units, or if a such a supply would be very complex or costly.

### Direct-acting valves

On the direct-acting solenoid valve, the medium flow is switched directly by the armature moved by the magnetic force – unlike on the servo-assisted solenoid valve. In this case, the valve opening (the passage) is generally closed off when de-energized by the armature by means of spring force. When electromagnetically excited, the sealing armature is moved away which cancels the sealing function and releases the passage. Thus, on the 2-way plunger-type valve, the core spring, assisted by the medium pressure, forces the valve seal onto the valve seat and closes the passage. After energization, the core is pulled with the seal into the solenoid coil. The valve opens. In this case, the electromagnetic force must be higher than the sum of spring force, static and dynamic pressure force.

### Duty cycle

The time between activation and deactivation of the solenoid system excitation current is referred as the duty cycle. The sum of duty cycle and idle interval is the cycle period. The term “relative duty” (%) means the percentage ratio of duty cycle to cycle period:  $\text{relative duty} = (\text{duty cycle}/\text{cycle period}) \times 100$  [%]. The term “continuous duty” means the duty mode in which the duty cycle lasts until the steady-state temperature is reached in practical terms (100 % duty) as the result of heating of the solenoid.

### Electrical control cabinets and solenoid valves

§13 of Standard VDE 0113, Part 1 (EN 60204, Part 1), pertaining to electrical equipment of machinery contains stipulations on the arrangement, mechanical construction and enclosure of switchgear devices. The formulation in Art. 13, Para. 2.2, refers to solenoid valves. The wording is as follows:

“Non-electrical parts and equipment which are not directly a part of the electrical equipment may not be arranged within the enclosures for switch cabinets. Equipment such as solenoid valves should be separate from the other electrical equipment (e.g. in a separate compartment).”

**Comment:** Since the Standard uses the words “should be separated” in the subjunctive, separation is recommended but not clearly required. In addition, on the automation systems referred to as AirLINES, the pilot valves and electronic modules are part of a subassembly and are thus also directly a part of the electrical equipment. Installation of AirLINES and valve islands with fieldbus interface in control cabinets is thus permitted. When doing this, it should be ensured that installation work is only performed by correspondingly trained and authorized specialists using ex-treme care and appropriate tools.

### Flow direction in solenoid valves

In most cases, full operability of a pilot valve is linked to defined flow directions of the medium for design-related purposes (e.g. on servo-assisted valves). If these flow directions are not complied with, this may cause failure of the switching function or may reduce pressure compatibility. The flow directions are defined via the ports (1 = pressure port; 2 and 4 = service ports which are supplied by the pressure port 1, i.e. flow direction from 1 to 2 or from 1 to 4; 3 and 5 = venting ports for the volumes aerated from the service ports, i.e. flow directions from 2 to 3 or from 4 to 5). The flow direction can be seen from the direction of the arrow in the circuit symbol indicating the circuit function (see table with selected circuit functions).

In special cases, flow in both directions is permitted with no restriction in function. The flow directions of these valves are identified with arrows pointing in both directions in the circuit symbols.

### Flow rates $K_v$ and $Q_{Nn}$

The crucial flow parameter for selecting a valve through which a fluid flows is the  $K_v$ -value in accordance with VDI/VDE 2173. This value is a water flow rate in  $m^3/h$ , referred to specific standard conditions and determined by measurement with water at  $+5\text{ °C}$  to  $+30\text{ °C}$  and at 1 bar pressure drop across the valve through which water is flowing. The  $K_v$  value for every valve (solenoid or process valve) is specified in the data sheet.

From the standardized  $K_v$  value, it is possible to calculate the real flow rate if the application conditions, such as pressure drop and fluid density, are known. An adequate flow rate, the  $Q_{Nn}$  value, has been defined for pneumatic valves through which gases flow. This flow rate  $Q_{Nn}$  is measured in  $l/min$  at 6 bar input pressure,  $+20\text{ °C}$  ambient temperature and 1 bar pressure drop across the valve. The relationship between  $Q_{Nn}$  and  $K_v$  value can be calculated in sub-critical flow state  $P_2 < 1/2 P_1$  in accordance with the equation  $Q_{Nn} [l/min] = 1078 K_v [m^3/h]$ .

### Heating of solenoid valve coils

Heat is generated in the solenoid coils of the pilot valves. Standard-design Bürkert solenoid valves feature relatively low temperatures at the solenoid coil. These temperatures are maximum  $+85\text{ °C}$  with continuous duty and a 10 % overvoltage.

In addition, ambient temperatures up to  $+50\text{ °C}$  may still occur in general. The permitted temperatures of the media to be switched in the process valves also depend on the relevant seal and valve material and may be up to  $+250\text{ °C}$  on selected products.

### Intermediate infeeds in the case of valve blocks or valve islands with fieldbus interface

Depending on valve size, air demand in the actuator, line length from the pilot valve to the actuator and cycling rate typical of the process, a valve group (e.g. valves on a valve islands with fieldbus interface) is supplied with pilot air from the pneumatic network via an infeed point. Very high air demand, long connections lines and parallel operation of several valves due to system-related simultaneous switching can lead to cases in which the pilot air infeed is insufficient and breaks down. In such cases, an intermediate or additional infeed is re-

quired. The basic pneumatic modules and pneumatic connector modules of the valve blocks with fieldbus interface are prepared for such intermediate or additional infeeds. These additional infeeds may comprise separate infeeds via mutually separate aeration and venting ducts or superimposed infeeds with interconnected aeration.

### Manual overrides

Pneumatic valves may be optionally equipped with manual overrides. These manual overrides can be used to manually move the solenoid valves to a mechanically locked position. Such manual overrides facilitate potential fault-finding, enable an emergency-stop function and, in the case of a large number of actuators to be controlled, facilitate systematic commissioning as well.

### Mufflers

Mufflers are used for reducing the noise produced when “disposing” of compressed air that is no longer required – as the result of venting a volume to the atmosphere. The sound pressure level is a measure of the volume of a noise, referred to the human auditory threshold. It is specified in decibels (dB) after passing a filter adapted to the human ear and designated A in dB(A). The permitted sound level depends upon the application (depending on the environment). In order to achieve a good muffling effect, the goal is to ensure the unhindered escape of the compressed air wherever possible, which necessitates as large a muffler filter area as possible.

If using valve islands with fieldbus interface, the exhaust air can be collected in central lines (ducted exhaust air) and routed to the outside in order to reduce the sound level and save on mufflers.

If using this procedure, it must be ensured that the exhaust air ducts are as large as possible in order to prevent retroactive effects of the collected exhaust air (which may have also possibly caused congestion) on the switching behavior of the valves.

#### **Operating voltages, voltage tolerances**

All solenoid-operated control valves for pneumatic actuators are chiefly designed for operating voltages 24 V DC and 24, 110 and 230 V, 50 Hz conventional in the various branches of industry. Solenoid actuators with other voltages are available. The permitted voltage tolerances normally amount to  $\pm 10\%$ . Deviations from this tolerance are listed in the data sheet. Conversion between the operating voltages can be very easily implemented if necessary by replacing the push-over coil.

#### **Pilot valves response times**

To date, the time between electrical switching to pressure build-up from 0 to 90 %, or pressure reduction from 100 to 10 % of the pilot pressure at the outlet of the service port has been designated as the response time of a valve in accordance with VDI Recommendation 3290 dated November 1962. Measurement is conducted at the valve outlet at 6 bar pilot pressure and at +20 °C. Response times are normally specified in milliseconds [ms].

ISO Standard 12238 dated July 2001 now stipulates pressure build-up from 0 to 10 % and pressure reduction from 100 to 90 % of the nominal pressure for determining the response time. The background of this standard relates to the fact that the differing volumes of the pressure transducers and their ports should not essentially influence the measurement results, particularly in the case of valves with small nominal diameters. As a logical consequence, shorter response times than in accordance with the previously valid standard are determined with this measuring procedure.

The relevant measurement conditions are specified in the data sheets. The real response times of a valve are influenced by the medium pressure to be switched, the masses to be moved, the magnetic forces acting on the armature as well as the spring forces and frictional forces in the valve. The valves developed and manufactured by Bürkert all feature low moving masses and relatively high magnetic forces in order to implement short response times.

#### **Pressure information**

All pressure information in the data sheets for Bürkert equipment is gauge pressure information above the relevant atmospheric pressure prevailing (relative pressure). The pressure information is specified in bar. In English-speaking countries, 1 bar = 14.2 psi (pounds per square inch). If using direct-acting solenoid valves in vacuum applications, it must be ensured that the partial vacuum is on the service port side. The higher pressure or the atmospheric pressure must be applied to the pressure inlet.

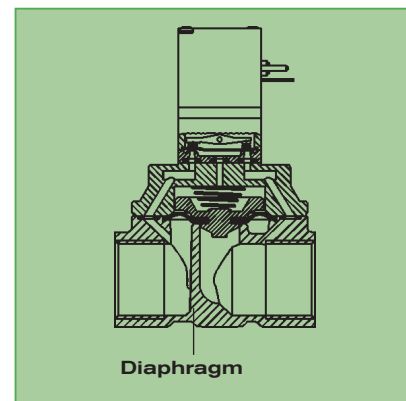

#### **Push-over solenoid coils**

Bürkert pilot valves are generally equipped with push-over coils for various voltages and rating classes. The push-over coils consist of an iron core and a coil made of copper wire with plastic sheathing. They are normally pushed over the core guide tube, which is permanently connected to the valve, fixed in position and locked with a nut. The coil position may be rotated around the core guide tube as required (360°) and locked in four fixed positions. It is a very simple procedure to replace a coil or convert to a different operating voltage by exchanging the push-over coil. For electrical connection, the solenoid coils feature tag connectors in accordance with DIN 43650, Type A, B or C. This allows the electrical connection to be very simply implemented with an appropriate appliance plug socket.

### Selecting a valve

One important criterion when selecting a pilot valve is whether the quantity of fluid required for the actuator per unit of time is able to flow through the valve with the solenoid valve fully open (on-off valve), i.e. the valve cross-section must be adequately large. For practical applications, it frequently suffices to select the connection cross-section of the pilot valve equal to that of the actuator. In addition, it is required that the process valve be able to switch the maximum occurring medium pressure in the valve, i.e. the pilot pressure must be adequately high and the valve actuator must be appropriately powerful. The maximum switchable medium pressure is specified in the data sheet.

Finally, when selecting a pilot valve, it is also necessary to note the correct circuit function, i.e. number of ports and switch positions and the required normal (de-energized) switch position. Certain passages are open or closed. The terms NC = normally closed and NO = normally open are increasingly being used in German as well. If the speed of the actuating element (e.g. piston in the cylinder) becomes excessive with the selected pilot valve, it is advisable to reduce the pilot pressure or to use restrictor valves in the supply line between the pilot valve and actuator.

A pilot valve should be well-matched to the actuator wherever possible. If it is underdimensioned (nominal diameter/flow rate too low), the process valve will switch only very slowly. If it is overdimensioned (nominal diameter/flow rate too high), there is risk of destroying the actuator and final control element.

### Service life, lubrication and wear

A valve's "service life" refers to the number of cycles achieved by a valve. Today, pneumatic valves feature lifetime lubrication. Consequently, additional lubrication with lubricated air is not usually required for operation of a valve.

Exceptions are listed in the data sheet. Sometimes, special cylinders, piston actuators or rotary actuators require lubrication of the compressed air. Only oils prescribed by the manufacturer may be used in this case. Some pneumatic valves are subject to high wear due to design reasons. This applies, in particular, to the seals of spool valves. The wear leads to leakage phenomena and must be checked regularly. If the leakage rate at 6 bar exceeds the upper limit of 0.5 % of the nominal volume flow, the valve should be replaced or repaired.

### Servo-assisted valves

On direct-acting valves, the static pressure force acting on the core increases with increasing seat diameter, and a correspondingly higher magnetic force (large coil with high power demand) is then required to overcome it. This is why servo-assisted solenoid valves on which the medium pressure opens and closes the medium flow are mainly used for switching higher pressures with larger nominal diameters. Servo-assisted valves have a 2-way or 3-way pilot valve (see drawing). A piston or a diaphragm in the valve serves to seal off the actual valve seat. In the case outlined, the applied medium pressure may build up on both sides of the diaphragm via a restrictor port with the pilot valve closed. A closing force – resulting from the larger area on the upper side of the diaphragm – continues to be in effect as long as there is a pressure differential between the

inlet and outlet of the valve. If the pilot valve is opened, the pressure above the diaphragm is reduced. The thus increasing force on the underside lifts the diaphragm and opens the valve. Servo-assisted valves require a minimum pressure drop across the valve for complete opening and closing. A forcibly lifted valve is produced by coupling the solenoid core to the diaphragm – generally by means of a spring. On this type of construction, no minimum pressure drop across the valve is required. Forcibly lifted valves already switch as of 0 bar.

### Simultaneity factor on valve islands with fieldbus interface

Depending on the control valve size, air demand in the actuator, line length from the pilot valve to the actuator and cycling rate typical of the process, a group of pilot valves (e.g. as a part of a valve island with fieldbus interface) is supplied via an infeed point with compressed air from the pneumatic network. Empirical values are available in relation to the number of pilot valves to be supplied from one infeed point. However, switching situations in which the supply breaks down may occur with very high air demand, long lines and control-related parallel operation of several valves.

An additional infeed is required in such cases. The basic pneumatic modules and pneumatic connector modules of the valve islands with fieldbus interface are prepared for such additional infeeds. These additional infeeds can be separate infeeds via mutually separate aeration and venting ducts or superimposed infeeds with interconnected aeration and venting ducts. The specific number of required additional infeeds depends on the specific application.

**Switching errors due to congestion in the exhaust duct****Integrated check valves in the R-channel**

On valve islands with fieldbus interface, the exhaust air for venting the actuators is generally routed to the outside via central exhaust air lines, where it is relieved via mufflers into the atmosphere in order to reduce the sound pressure level and save on mufflers. In this case, the exhaust air to be relieved is collected in the exhaust air lines. If this exhaust air is not relieved quickly enough into the atmosphere, a pressure which delays closure of the process valves can build up in these lines. More rapid pressure reduction in the exhaust air lines helps to remedy this situation. This can be done with additional or higher volume exhaust air lines, additional supply or exhaust air modules and with quick-exhaust valves. This air congestion in valve blocks with fieldbus interface or in conventional valve blocks can also lead to idle pilot valves passing on the pressure to their outlet, thus causing a process valve to unintentionally open for a short period of time. This may result in major damage to the process. In order to counteract these problems, i.e. to offer a technical solution, check valves may be integrated in the exhaust air ducts in the basic pneumatic modules. This measure precludes the possibility of unintentional switching as a result of air congestion.

**Temperature ranges for pneumatic solenoid valves**

The limits for the ambient temperature are listed in the data sheets of the solenoid valves for pneumatics. The temperature of the pilot air is equated with these temperature ranges. If these temperature limits are exceeded by the ambient conditions, problems may occur with the seals or with other materials used.

In applications in the temperature range below zero degrees Celsius (frost range), only absolutely dry pilot air may be used since, otherwise, there is a very real risk of the control valve and actuator freezing up.

**Valve replacement in ongoing operation****Integrated check valve in the P-channel**

The valve blocks with fieldbus interface can be optionally equipped with a P shut-off. This P shut-off allows replacement of a valve without having to depressurize the entire valve block with fieldbus interface. With the P shut-off, a mechanism seals, apart from minor residual leakage when the valve is removed, the cross-section of the P port pertaining to the valve. The valves remaining on the valve block can continue to be operated unrestrictedly with the valve removed. When a new valve is fitted, the P shut-off is reopened automatically.

All technical details were valid at the time of going to print. Since we are continuously developing our products, we reserve the right to make technical alterations. Unfortunately, we also cannot fully exclude possible errors. Please understand that no legal claims can be made based upon either the details given or the illustrations and descriptions provided.

Texts, photographs, technical drawings and any other form of presentations made in this publication are protected by copyright and property of Bürkert Fluid Control Systems GmbH & Co. KG.

Any further use in print or electronic media requires the express approval of Bürkert GmbH & Co. KG. Any form of duplication, translation, processing, recording on microfilm or saving in electronic systems is prohibited without the express approval of Bürkert GmbH & Co. KG.

Bürkert GmbH & Co. KG  
Fluid Control Systems  
Christian-Bürkert-Straße 13-17  
D-74653 Ingelfingen



**Burkert Service and  
Distribution Network**

**Australia**

Burkert Fluid Control Systems  
No. 2 Welder Road,  
Seven Hills, NSW 2147  
Tel. +61 1300 888 868  
Fax +61 1300 888 076

**Austria**

Burkert-Contromatic Ges.m.b.H.  
Diefenbachgasse 1-3  
1150 Wien (Vienna)  
Tel. +43 (0) 1 894 13 33  
Fax +43 (0) 1 894 13 00

**Belgium**

Burkert-Contromatic SA  
Bijkhoevelaan 3  
2110 Wijnegem  
Tel. +32 (0) 3 325 89 00  
Fax +32 (0) 3 325 61 61

**Brazil**

Burkert-Contromatic Brasil Ltda.  
Rua Américo Brasiliense  
no. 2171 cj 1007  
04715-005 São Paulo - SP  
Tel. +55 (0) 11 5182 0011  
Fax +55 (0) 11 5182 8899

**Canada**

Burkert Contromatic Inc.  
760 Pacific Road, Unit 3  
Oakville (Ontario) L6L 6M5  
Tel. +1 905 847-55 66  
Fax +1 905 847-90 06

**China**

Burkert Contromatic (Suzhou) Co., Ltd.  
9-2 Zhu Yuan Road,  
Suzhou New District  
Jiangsu, China. 215011  
Tel. +86 512 6808 19 16  
Fax +86 512 6824 51 06

**Czech Republic**

Burkert-Contromatic Ges.m.b.H.  
Branch-Office Austria  
Krenova 35  
602 00 Brno  
Tel. +42 05 43 25 25 05  
Fax +42 05 43 25 25 06

**Denmark**

Burkert-Contromatic A/S  
Hørkær 24  
2730 Herlev  
Tel. +45 44 50 75 00  
Fax +45 44 50 75 75

**Finland**

Burkert Oy  
Atomitie 5  
00370 Helsinki  
Tel. +358 (0) 9 549 70 600  
Fax +358 (0) 9 503 12 75

**France**

Burkert Contromatic France  
Rue du Giessen  
BP 21  
67220 Triembach au Val  
Tel. +33 (0) 3 88 58 91 11  
Fax +33 (0) 3 88 57 20 08

**Germany**

Bürkert GmbH & Co. KG  
Christian-Bürkert-Straße 13-17  
D-74653 Ingelfingen  
Tel. +49 (0) 7940 10 111  
Fax +49 (0) 7940 10 448

**Hong Kong**

Burkert-Contromatic (China/HK) Ltd.  
Unit 708, Prosperity Centre  
77-81, Container Port Road  
Kwai Chung N.T., Hong Kong  
Tel. +85 2 2480 1202  
Fax +85 2 2418 1945

**Italy**

Burkert Contromatic Italiana S.p.A.  
Centro Direzionale „Colombiolo“  
Via Roma 74  
20060 Cassina De' Pecchi (Mi)  
Tel. +39 02 95 90 71  
Fax +39 02 95 90 72 51

**Japan**

Burkert-Contromatic Ltd.  
1-8-5 Asagaya Minami  
Suginami-ku  
Tokyo 166-0004  
Tel. +81 (0) 3 5305 3610  
Fax +81 (0) 3 5305 3611

**Korea**

Burkert Contromatic Korea Co., Ltd.  
287-2, Doksan 4 Dong  
Kumcheon-ku  
Seoul 153-811  
Tel. +82 (0) 3 3462 5592  
Fax +82 (0) 3 3462 5594

**Netherlands**

Burkert-Contromatic BV  
Computerweg 9  
3542 DP Utrecht  
Tel. +31 (0) 346 58 10 10  
Fax +31 (0) 346 56 37 17

**New Zealand**

Burkert Contromatic Ltd.  
2A, Unit L, Edinburgh St  
Penrose, Auckland  
Tel. +64 (0) 9 622 2840  
Fax +64 (0) 9 622 2847

**Norway**

Burkert Contromatic A/S  
Hvamstubben 17  
2013 Skjetten  
Tel. +47 63 84 44 10  
Fax +47 63 84 44 55

**Philippines**

Burkert Contromatic Philippines, Inc.  
8467 West Service Road  
South Superhighway, Sunvalley  
Paranaque City, Metro Manilla  
Tel. +63 2 776 43 84  
Fax +63 2 776 43 82

**Poland**

Burkert-Contromatic Ges.m.b.H.  
Branch-Office Austria  
Bernardynska street 14 a  
02-904 Warszawa  
Tel. +48 22 840 60 10  
Fax +48 22 840 60 11

**Portugal**

Burkert Contromatic  
Tel. +351 21 382 80 00  
Fax +351 21 387 36 79

**Singapore**

Burkert Contromatic  
Singapore Pte. Ltd.  
51 Ubi Avenue 1, #03-14  
Paya Ubi Industrial Park  
Tel. +65 6844 2233  
Fax +65 6844 3532

**South Africa**

Burkert Contromatic (Pty) Ltd.  
233 Albert Amon Road  
Millenium Business Park  
Meadowale  
Edenvale  
Tel. +27 (0) 11 397 2900  
Fax +27 (0) 11 397 4428

**Spain**

Burkert Contromatic S.A.  
Avda. Barcelona, 40  
08970 Sant Joan Despi (Barcelona)  
Tel. +34 93 477 79 80  
Fax +34 93 477 79 81

**Sweden**

Burkert-Contromatic AB  
Skeppsbron 13 B  
211 20 Malmö  
Tel. +46 (0) 40 664 51 00  
Fax +46 (0) 40 664 51 01

**Switzerland**

Burkert-Contromatic AG Schweiz  
Bösch 71  
6331 Hünenberg  
Tel. +41 (0) 41 785 66 66  
Fax +41 (0) 41 785 66 33

**Taiwan**

Burkert Contromatic Taiwan Ltd.  
3F, No. 475, Kuang-Fu South Road  
Taipei, Taiwan  
Tel. +886 (0) 2 2758 3199  
Fax +886 (0) 2 2758 2499

**Turkey**

Burkert Contromatic Akiskan  
Kontrol Sistemleri Ticaret A.S.  
1203/8 Sok. No 2-E  
Yenisehir, Izmir  
Tel. +90 (0) 232 459 53 95  
Fax +90 (0) 232 459 76 94

**United Kingdom**

Burkert Fluid Control Systems  
Brimmscombe Port Business Park  
Brimmscombe, Stroud, Glos., GL5 2QF  
Tel. +44 (0) 1453 73 13 53  
Fax +44 (0) 1453 73 13 43

**USA**

Burkert Contromatic USA  
2602 McGaw Avenue  
Irvine, CA 92614  
U.S.A.  
Tel. +1 949 223 3100  
Fax +1 949 223 3198

Information paves the path to the appropriate system solution. We provide five different levels for accessing information, products and services, so that you can easily find out everything you need to know to make the right choice.

**Service brochure**

A systematic overview of the range of products and services offered by Bürkert. A network of comprehensive solutions integrating coordinated services.



**Competence brochures**

Essential information for the person planning control loops and field bus systems and who wants to ensure basic knowledge of the structure and selection of system components.



**Application brochures**

Example applications for deriving the appropriate system solution, supplemented by information on product advantages, user advantages and the range of products specifically available.



**System catalogs**

Background knowledge on product technology, including an up-to-date overview of the current offers. Rounded out with information to help you make your decision on the best application option.

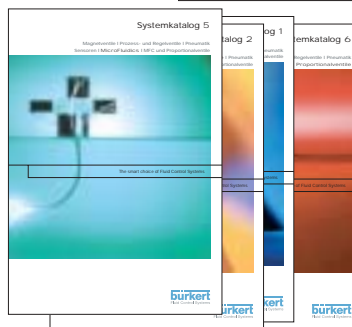

**Technical data sheets**

Detailed technical information for checking specific suitability. In addition, all the data needed for direct ordering.





