

Level Gauge & Transmitter

Series **LT10/LTL10**



LT10 Liquid Level Gauge & Transmitter

Working pressure manufacturing according to
PED 97/23/CE (Lloyd's Register Certificate N° 031)

Simply constructed and resistant to adverse conditions of temperature and pressure. Materials in EN 1.4404 (SS 316L), PVC, PP, PVDF or PTFE for most applications in industries such as:

- Chemical, petrochemical and other processes
- Refrigeration, Retorts and Heat Treatment
- Boilers, marine & industrial
- Evaporators & Condensers
- Storage Tanks

Features

- Full process isolation, no risk of leakage
- Alarms contacts adjustable over the full range
- Clear indication with magnetic float or magnetic strips
- Transmitter output 0...4-20 mA
- Excellent chemical and mechanical resistance

Operation

A vertical measuring chamber, connected to the tank at each end, contains a magnetic float that rises and falls with the liquid level. An indicating chamber is attached, but not directly connected, to the measuring chamber. The indicating chamber contains a magnetic strips indicator or magnetic float that follows the position of the float in the measuring chamber to provide an indication of the tank level.

Adjustable contacts, actuated by the float's magnetic field, can provide switch points for control or alarms. A sensor detecting the float position can provide a 4-20 mA signal for proportional control.

(On request HART, PROFIBUS, FIELDBUS protocol)



Technical Data

- Installation: Vertical, parallel to the tank
 - Connections: DN25 PN16 DIN Flanges EN 1092-1
(On request, ASA, JIS and others)
THREAD 1/2...3" BSP/NPT
 - Accuracy: $\pm 3...4$ mm
 - Scale: cm (% and volume on request)
 - Density: 0.45 to 3 kg/ l
 - Viscosity: Maximum 1500 cSt ($1500 \text{ mm}^2 \cdot \text{s}^{-1}$)
 - Working pressure manufacturing according to PED 97/23/CE (Lloyd's Register Certificate N° 031)
 - Pressure: 16 bar for EN 1.4404 (SS 316L) (Std), PTFE, PVDF
400 bar for EN 1.4404 (SS 316L) (Special)
10 bar for PVC, PP, PVDF
 - Temperature: -20°C to + 150°C EN 1.4404 (SS 316L) (Std) & PTFE
-150°C to + 400°C EN 1.4404 (SS 316L)(Special)
0°C to + 50°C PVC
-10°C to + 90°C PP
-20°C +130°C PVDF
 - Length: Max 6,000mm for EN 1.4404 (SS 316L) (Std) & PTFE, PVDF, PP, PVC
Max 15,000mm for EN 1.4404 (SS 316L)(Special)
 - Accessories: Thermal or cooling chamber
 - Contacts:
 - AMM Micro-switch, 3A 220V
 - AMD Inductive proximity sensor with relay amplifier (3A 220V) intrinsic safety (NAMUR DIN 16234) as an option
 - AMR, APR Bi-stable reed switch (0.5A 250VAC 60VA)
 - ADF Explosion proof connector EExd IIC T6
 - Transmitter LTE: 0...4-20 mA, 220, 125, 24VAC or 24VDC
- (On request HART, PROFIBUS, FIELDBUS protocol)

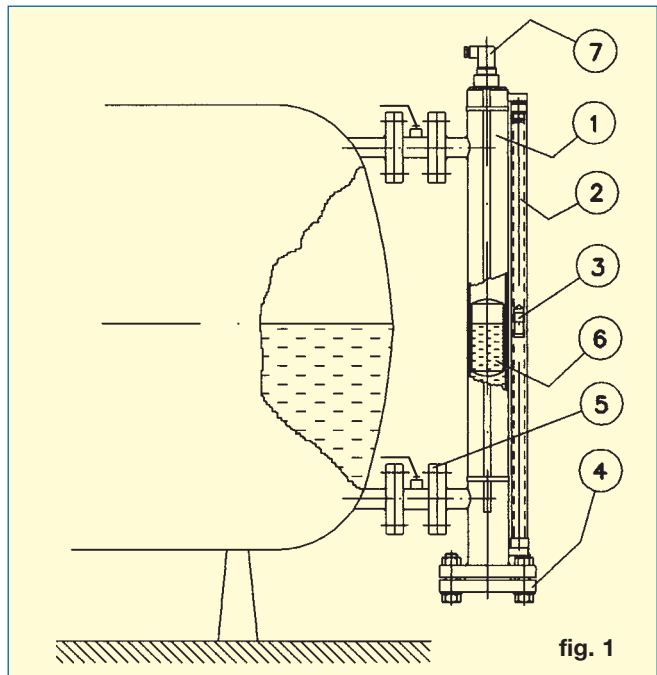

fig. 1

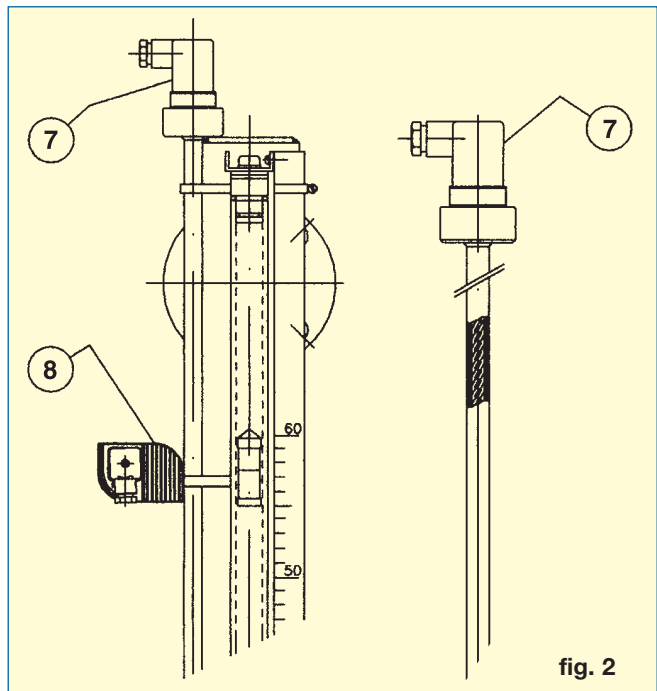

fig. 2

Material and Components

| Item | Part | LT...LTL/INOX | LT...LTL/PVC...PP...PVDF | LT...LTL/PTFE |
|------|--------------------|----------------------------|----------------------------|----------------------------|
| 1 | Body | EN 1.4404 (SS 316L) | PVC...PP...PVDF | PTFE + EN 1.4404 (SS 316L) |
| 2 | Indicating chamber | Borosilicate/Aluminium | Borosilicate/Aluminium | Borosilicate / Aluminium |
| 3 | Indicator | PP/Aluminium + Magnet | PP/Aluminium + Magnet | PP / Aluminium + Magnet |
| 4 | End Flange | EN 1.4404 (SS 316L) | PVC...PP...PVDF | PTFE + EN 1.4404 (SS 316L) |
| 5 | Connecting Flange | EN 1.4404 (SS 316L) | PVC...PP...PVDF | PTFE + EN 1.4404 (SS 316L) |
| 6 | Float | EN 1.4404 (SS 316L) | PVC...PP...PVDF | PTFE |
| 7 | Transmitter | EN 1.4404 (SS 316L) | EN 1.4404 (SS 316L)/PVC... | EN 1.4404 (SS 316L)/PTFE |
| 8 | Contacts | Micro-switch/Reed/Detector | Micro-switch/Reed/Detector | Micro-switch/Reed/Detector |

Series LT Level Gauge + LTE (Transmitter 4-20 mA)

Designed with separate functional components to enable the LT be adapted to individual application requirements. The base unit provides a level measurement which can include the following:

- Visual indication by float (LT) or magnetic strip (LTL)
- Adjustable alarm points (Hi/Lo), fig.2, n°8
- 0...4-20 mA transmitter signal, fig. 1/ fig. 2, n°7

Float Level Indication (Series LT...)

A borosilicate glass tube, containing a magnetic float, is attached to the measuring chamber. The magnetic float follows the float in the measuring chamber to provide a visual indication of the liquid level. The indicating chamber has a graduated scale in cm.

Maximum INTERNAL OPERATING TEMPERATURE

- LT with external indicator float:
 - PP maximum 150°C
 - Aluminium maximum 350°C
 - PTFE maximum 350°C

Magnetic Strips Level Indication (Series LT...LTL)

An aluminium tube assembly containing a Polycarbonate transparent cover is attached to the front of the measuring chamber. The assembly contains a column of bi-colour magnetic strips that form a vertical band to provide a fast visual indication of the fluid level.

Maximum INTERNAL OPERATING TEMPERATURE

- LTL with magnetic strips indicator:
 - Plastic maximum 160°C
 - Aluminium maximum 400°C

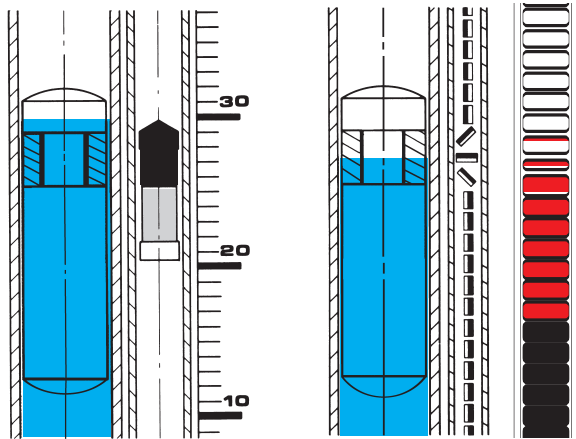

External float indicator (LT)

Magnetic strip indicator (LTL)

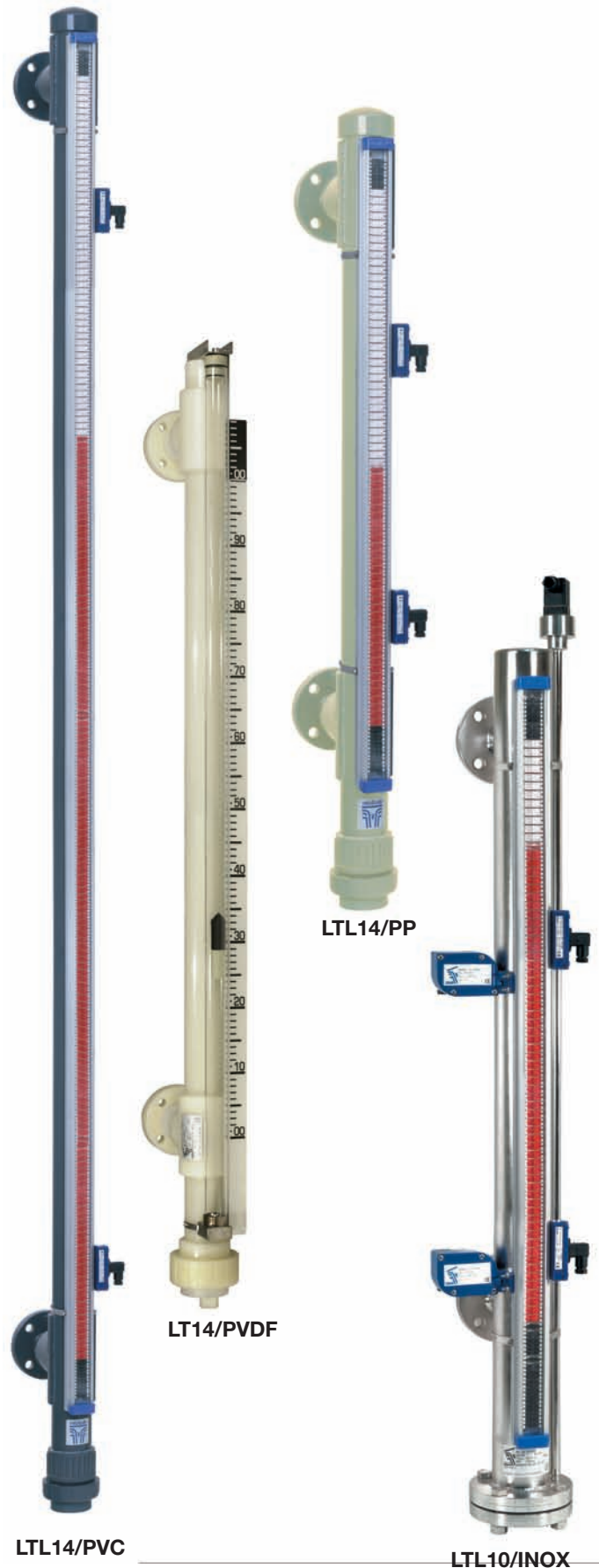

LTL14/PVC

LT14/PVDF

LTL14/PP

LTL10/INOX

Standard

Series LT10/SS and LT11
Magnetic Level Indication (float)
Series LTL10/LTL11
Strips level indication
EN 1.4404 (SS 316L) PN16...PN40

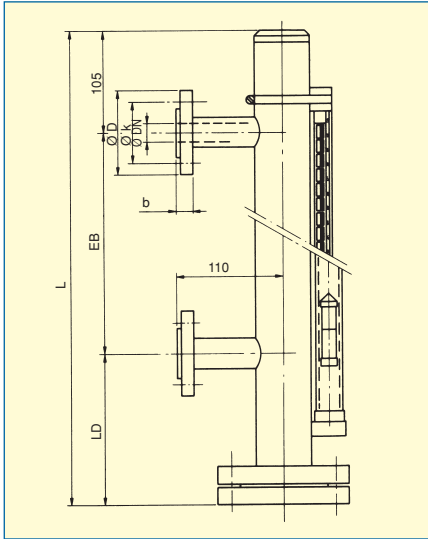

Technical Data

- Material: EN 1.4404 (SS 316L)
- Length EB: 6,000mm max
15,000mm (Special)
- Flange LT-10: DN25 PN16...PN40
DN20 PN16...PN40
- Thread LT-11: 1" BSP/NPT
1/2" and 3/4" BSP/NPT
- Temperature: -20°C +150°C (Std)
-150°C +400°C (Spec)
- Floats: see page 6
- Alarms: LT-AMM, LT-AMD (LTL-AMM, AMD)
LT-AMR, LT-APR (LTL-AMR, APR)
- Output: LTE (0...4.20 mA)

High pressures

Series LT16/SS
Magnetic Level Indication (float)
Series LTL16/SS
Strips level indication
EN 1.4404 (SS 316L) PN64...PN400

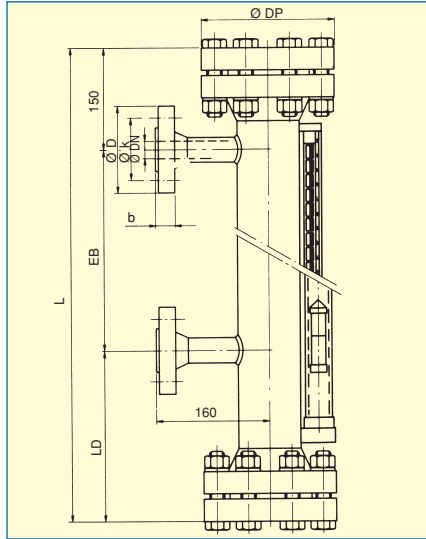

Technical Data

- Material: EN 1.4404 (SS 316L)
(others also available)
- Length EB: 6,000mm max
- Flange: DN25 PN64...PN 400
(on request ASA, JIS)
- Temperature: -20°C +150°C (Std)
-120°C +400°C (Spec)
- Floats: See page 6
- Alarms: LT-AMM, LT-AMD (LTL-AMM, AMD)
LT-AMR, LT-APR (LTL-AMR, APR)
- Output: LTE (0...4-20 mA)

Boilers

Series LT19/SS
Magnetic Level Indication (float)
Series LTL19/SS
Strips level indication
EN 1.4404 (SS 316L) PN16...PN64

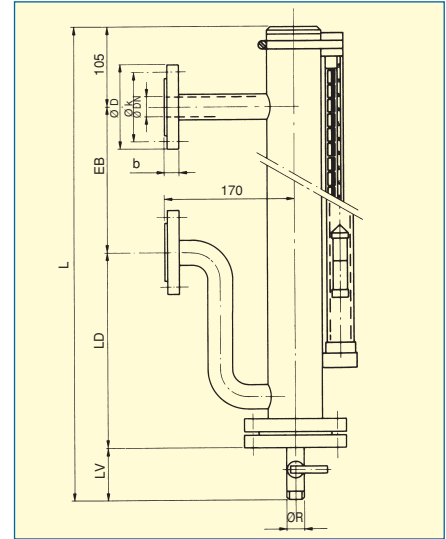

Technical Data

- Material: EN 1.4404 (SS 316L)
(others also available)
- Length EB: 6,000mm max
- Flange: DN25 PN40
DN20 PN40
- Temperature: -20°C +150°C (Std)
-120°C +400°C (Spec)
- Floats: See page 6
- Alarms: LT-AMM, LT-AMD (LTL-AMM, AMD)
LT-AMR, LT-APR (LTL-AMR..APR)
- Output: LTE (0...4-20 mA)

Connections Detail

LTL11/INOX

LTL10/INOX



LD distance for mounting the level gauge

| Density liquid (min) kg/l | Series | Series |
|---------------------------|--|--|
| | LT10, LTL10 LT11, LTL11 LT19, LTL19 LT15, LTL15 | LT14, LTL14 LT14PP, LTL14 PP LT14PV, LTL14PV |
| 0,920 ≥ | LD=286 | LD=240 |
| 0,810 ≥ | LD=362 | LD=310 |
| 0,600 ≥ | LD=456 | LD=400 |

With heating chamber
Series LTGCBR
Hi & Lo Temperature Cover
for LT and LTL 10, 11, 15 & 19

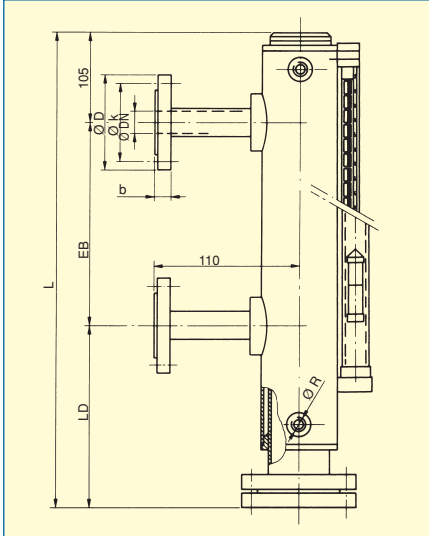

Technical Data

- Material: EN 1.4404 (SS 316L) for LT10, 11, 15, 19
- Length EB: 6,000mm max
15,000mm (Special)
- Flanges: DN20 PN16...PN40
Threads: 3/4" BSP/NPT
1/2" and 3/4" BSP/NPT
- Temperature: EN 1.4404 (SS 316L) -20°C + 150°C
-150°C + 400°C (Special)
PP -10°C + 90°C
PVDF -20°C + 135°C

PTFE material
Series LT15/PTFE
Magnetic Level Indication (float)
Series LTL15/PTFE
Strips level indication

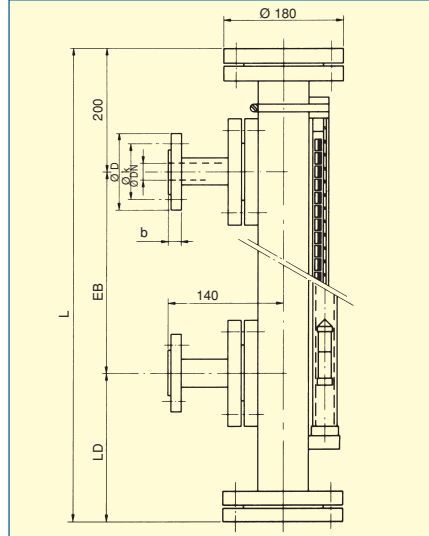

Technical Data

- Liner material: PTFE
- Exterior chamber: EN 1.4404 (SS 316L)
- Length EB: 6,000 mm max
- Flange: DN25 PN16
Others on request
- Temperature: -60°C +150°C
- Floats: See page 6
- Alarms: LT-AMM, LT-AMD (LTL-AMM, AMD)
LT-AMR, LT-APR (LTL-AMR, APR)
- Output: LTE (0...4-20 mA)

Plastics materials
Series LT14/PVC, LT14/PP, LT14/PV (PVDF)
Magnetic level indication (float)
Series LTL14 /PVC, LT14/PP, LTL14/PV
Strips level indication

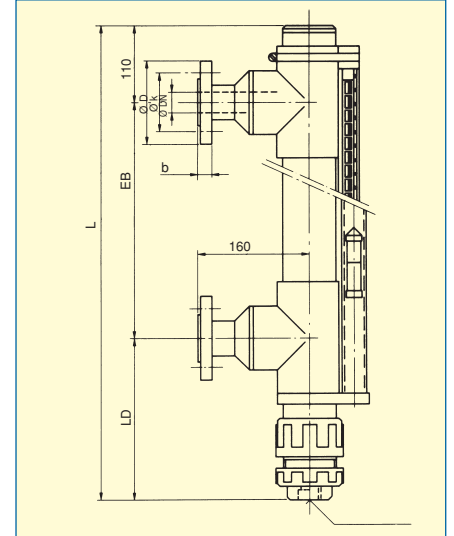

Technical Data

- Material: PVC, PP, PVDF
- Length EB: 6,000mm max
- Flange: DN25 PN10
Others on request
- Temperature: 0°C +45°C PVC
-10°C +90°C PP, PVDF
- Floats: See page 6
- Alarms: LT-AMM, LT-AMD (LTL-AMM, AMD)
LT-AMR & LT-APR (LTL-AMR, APR)
- Output: LTE (0...4-20 mA)

Very important:

The dimension LD of the lower part of the level depends on the liquid density. As the density falls, the dimension LD increases due to the increase of the float length. It is necessary to leave the same distance LD between the end of the level and the floor, as shown in fig. 3.

This clearance permits us to dismount the float for cleaning, servicing or changing the float for other liquid densities etc.

Also a minimum clearance of 130 mm should be left above the level if is fitted with a purge valve.

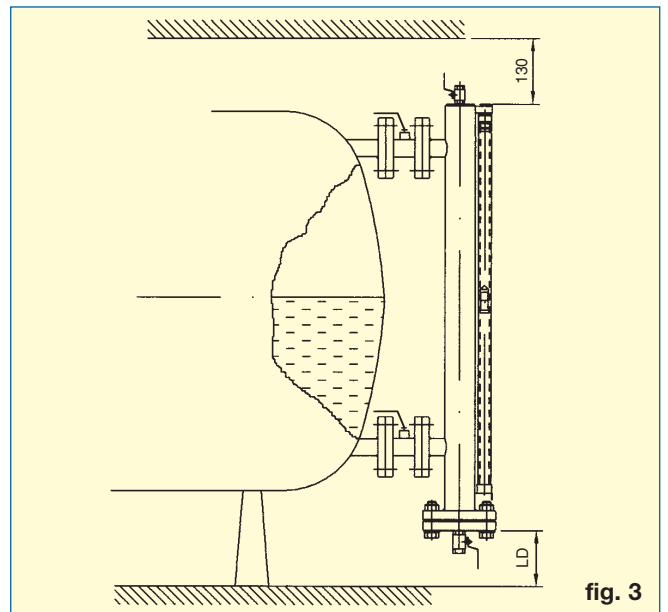
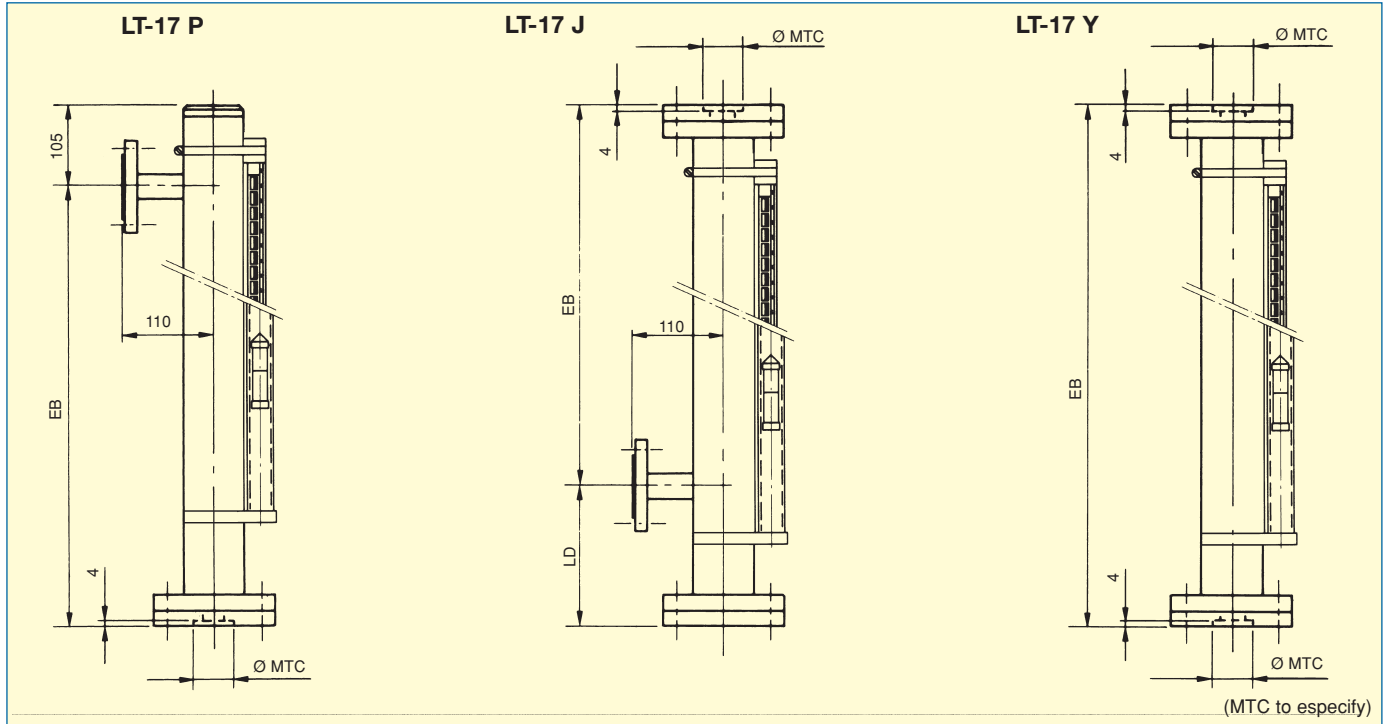
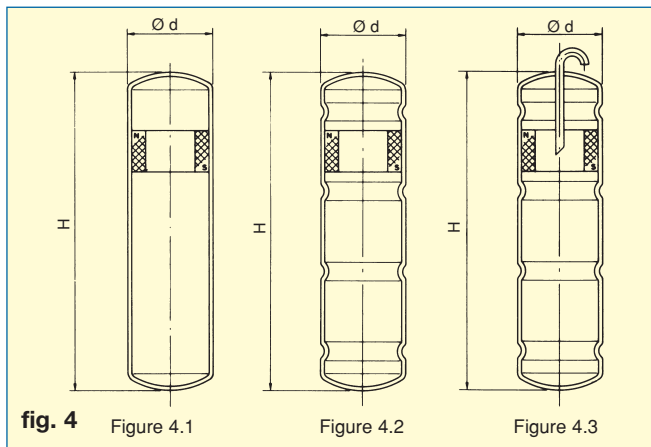

fig. 3

Special Mountings



LT/LTL Floats



For special applications, the floats can be built with different materials and for different working conditions to those shown.

Important!

The pressurisation of the floats should be carried out slowly to avoid sharp pressure charges. Pressure shocks may deform the floats. This is especially important for floats designed for high pressures and with compensation tubes.

The self regulating floats and floats with compensation tubes must not be used in applications with condensable gases and vapours.

| Model | Material | Figure | Minimum Density (kg/l) | | PN (bar) | max T°C | Ød | H |
|--------------------------------|--------------------------|--------|------------------------|-------|----------|---------|---------|-----|
| | | | LT | LTL | | | | |
| LTG...LTLG811 | EN 1.4404 ⁽²⁾ | 1 | 0,920 | 1,200 | 16 | 200 | 52...62 | 230 |
| LTG...LTLG812 | EN 1.4404 ⁽²⁾ | 1 | 0,870 | 0,920 | 16 | 200 | 52...62 | 280 |
| LTG...LTLG813 | EN 1.4404 | 1 | 0,810 | 0,860 | 10 | 200 | 52...62 | 330 |
| LTG...LTLG814 | EN 1.4404 | 1 | 0,700 | 0,750 | 10 | 200 | 52...62 | 430 |
| LTG...LTLG811R2 ⁽¹⁾ | EN 1.4404 | 2 | 0,920 | 1,200 | 25 | 200 | 52...62 | 230 |
| LTG...LTLG812R2 ⁽¹⁾ | EN 1.4404 | 2 | 0,870 | 0,920 | 25 | 200 | 52...62 | 280 |
| LTG...LTLG813R2 ⁽¹⁾ | EN 1.4404 | 2 | 0,810 | 0,860 | 25 | 200 | 52...62 | 330 |
| LTG...LTLG814R2 ⁽¹⁾ | EN 1.4404 | 2 | 0,700 | 0,750 | 25 | 200 | 52...62 | 430 |
| LTG...LTLG819R0 | EN 1.4404 | 3 | 0,870 | 0,920 | 100 | 200 | 52...62 | 330 |
| LTG...LTLG8T4 ⁽³⁾ | Titanio | 1 | 0,600 | 0,600 | 10 | 200 | 52...62 | 430 |
| LTG...LTLG8326 | PVC | 1 | 0,600 | 0,600 | 10 | 45 | 52...62 | 180 |
| LTG...LTLG8527 | PTFE | 1 | 0,700 | 0,700 | 10 | 150 | 52...62 | 200 |
| LTG...LTLG8916 | PP | 1 | 0,600 | 0,600 | 10 | 90 | 52...62 | 180 |
| LTG...LTLG8PV1 | PVDF | 1 | 0,700 | 0,700 | 10 | 135 | 52...62 | 180 |

⁽¹⁾ R4, 40 bar max. same density and temperature. R6, 64 bar max. same density and temperature.

⁽²⁾ EN 1.4404 actual denomination the SS 316L.

⁽³⁾ Same float with R4 up to 40 bar max.

Other pressure on order

Alarms

LT-AMM / LTL-AMM

- Painted aluminium enclosure to IP65
- Micro-switch based electrical contact.
- Potential free SPDT contacts
- Contact Rating: 3A, 250VAC
- Hysteresis: ± 6 mm
- Ambient Temp.: -25°C $+80^{\circ}\text{C}$
- Mechanical Life: 20×10^6 operations

LT-AMD/LTL-AMD

- Painted aluminium enclosure to IP65
- Inductive sensor based alarm for IS applications
- Nominal voltage: 8.2 Vdc
- Hysteresis: ± 5 mm
- Ambient Temp: -25°C $+70^{\circ}\text{C}$

On request Relay Amplifier NAMUR DIN 19234:

- 1 or 2 contacts rated to EEx ia IIC
- Contact Rating: 4A 250 VAC, 250 VA
- Supply: 220VAC, 45-60 Hz or 24VDC

LT-AMR/LTL-AMR

LT-AMRP/LTL-AMRP

LT-APR/LTL-APR (PVC enclosure IP65)

LT-AAR/LTL-AAR (Aluminium enclosure with radiator)

- Painted aluminium enclosure to IP65
- Bi-Stable reed switch based electrical contact
- Hysteresis: ± 6 mm
- Ambient Temp: -10°C $+70^{\circ}\text{C}$
- Contact Rating: 0.5A, 250VAC, 60VA

ADF Explosion Proof Enclosure EEx d IIC T6 (ATEX)



- Explosion proof connection for above alarm contacts

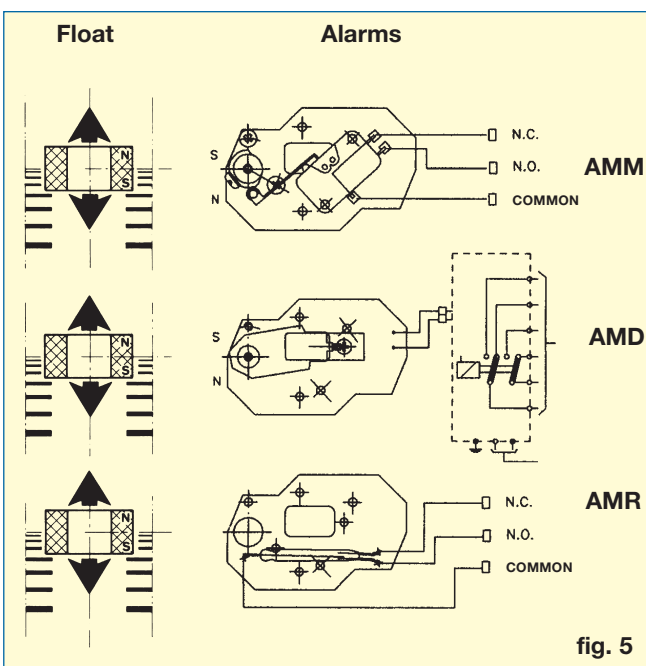

LT-AMM ... LT-AMD / LTL-AMM ... LTL-AMD / LT-AMR ... LTL-AMR

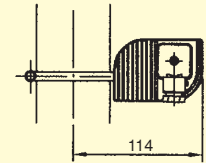
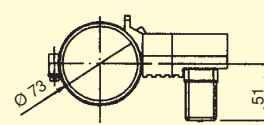

LT-AMRP

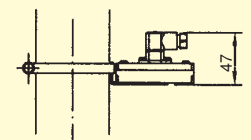
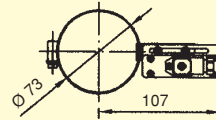

LTL-AMRP

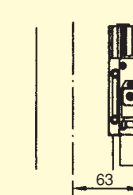
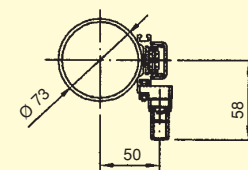

LT-APR ... LTL-APR

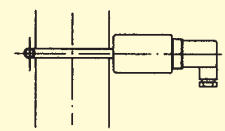
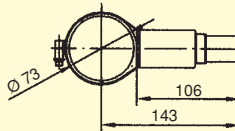

LT-AAR ... LTL-AAR

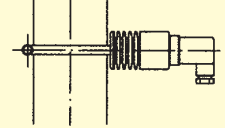
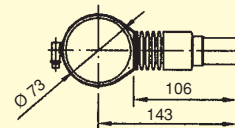

According to European Directive 94/9/EC (ATEX)

Group and category II 2GD EExd IIC T6 IP 67 T 85°C
Zones where applicable: Zones 1 and 2
Identification number 0163 (Laboratorio Oficial J.M. Madariaga)

LT-ADF / LTL-ADF

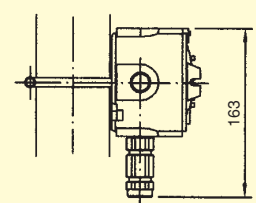
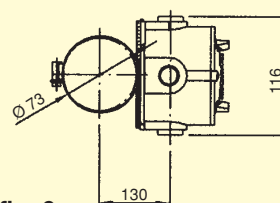
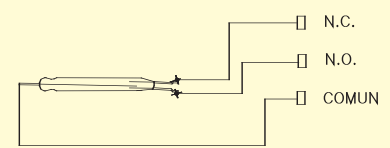
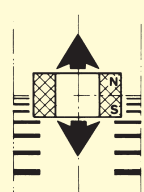

fig. 6

AMRP / APR / AAR



Level transmitter probe Series LTE (0...4-20 mA)

A reed switch and resistor chain is mounted on a PCB in the interior of the probe. The total length of the chain is the same as the maximum level difference to be measured.

An electronic unit converts from resistance to an analog output proportional to the level. The analog output can be connected to local indicators, recorders or control instruments. The maximum distance between the probe and the transmitter is 500 m.

Operation

The magnetic field of the float inside the LT level acts on the external reed-resistance chain.

The variations of level displace the float which acts on the reed-switches, changing the chain resistance to a new value. The variations of resistance are transmitted by the electronic unit giving an analog output proportional to the liquid level.

Level Indicator with transmitter

Series LT ... LTL10



LTE Operation

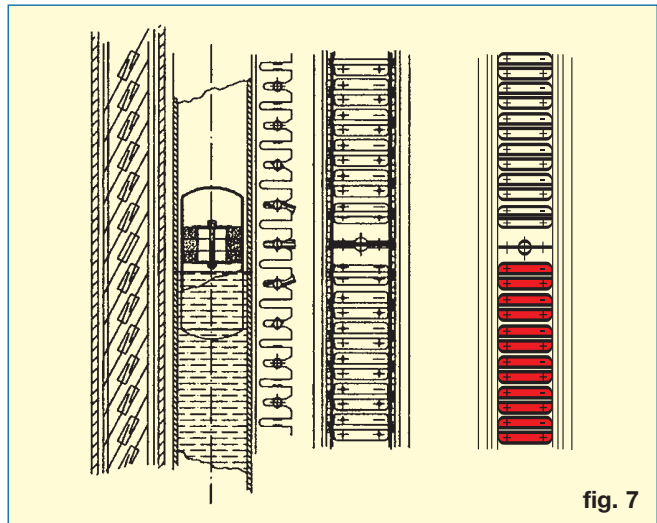

Series LT ... LTL11



Technical Data

Probe

- Reed separation: 10 mm
- Max Length: 6 m
- Temperature (Fluid): -20°C + 150°C

Electronics

- Enclosure: Aluminium, plastic, IP65 connector, ADF enclosure
- Mounting: Rail DIN 46277
- Power supply: 240, 220, 110 & 24 Vac; 50/60 Hz
24 Vdc
- Temperature Ambient: -20°C + 60°C
- Connection: 2 or 4 Wire
- Version EEx ia IIC T6 2 wires available
(On request with HART, PROFIBUS, FIELDBUS protocol)

Connection enclosure LTE

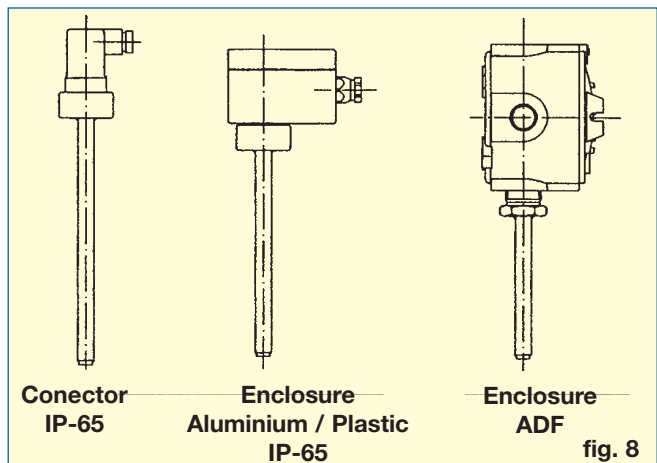

We are at your service, please consult us.

TECFLUID develops and manufactures instruments for gases and liquids, using the most advanced techniques.

Request information by telephone nº: +34 93 372 45 11