

SIMRAD GD10L - IR GAS DETECTOR OPERATING MANUAL

P3382E
May 2002



Designed for safety – Made for life

TABLE OF CONTENTS:

1. PRODUCT DESCRIPTION	1
1.1 INTRODUCTION	2
1.2 GENERAL DESCRIPTION	2
1.3 AREAS OF APPLICATION	2
1.4 PRINCIPLE OF MEASUREMENT	3
2. INSTALLATION	4
2.1 POSITIONING OF OPEN-PATH DETECTORS	4
2.2 MOUNTING OF THE DETECTOR AND REFLECTOR.....	4
2.2.1 <i>The following points should be taken into account when positioning open-path detectors</i>	4
2.3 ELECTRICAL CONNECTIONS	6
3. COMMISSIONING.....	6
3.1 PREPARATION	6
3.2 COARSE ALIGNMENT USING THE ADJUSTMENT SIGHT.....	7
3.2.1 <i>Procedure</i>	7
3.3 FINE-TUNING AND ZERO ADJUSTMENT USING THE HAND TERMINAL.....	8
3.3.1 <i>Procedure</i>	8
3.4 FUNCTION TEST.....	10
4. MAINTENANCE	10
4.1 REGULAR MAINTENANCE.....	10
4.2 TROUBLESHOOTING	10
5. TERMINAL.....	11
5.1 INTRODUCTION	11
5.2 DESCRIPTION OF TERMINAL	11
5.3 START-UP.....	12
5.4 FUNCTIONS	12
5.4.1 <i>Installation of detector</i>	12
5.4.2 <i>Display gas value</i>	12
5.4.3 <i>Fault messages</i>	13
6. TECHNICAL DATA	13
6.1 DETECTOR	13
6.2 ADJUSTABLE BRACKET FOR DETECTOR	14
6.3 REFLECTOR 20x20 CM.....	14
6.4 REFLECTOR 30x30 CM.....	14
6.5 TECHNICAL DATA, ACCESSORIES	14
6.5.1 <i>Gas filter</i>	14
6.5.2 <i>Adjusting sight</i>	14
6.5.3 <i>Hand terminal</i>	14
6.6 CERTIFICATIONS	15
6.7 CERTIFICATES	15
7. ORDERING INFORMATION	16

Table of figures

FIGURE 1-1 TRANSMISSION AS A FUNCTION OF WAVELENGTH	3
FIGURE 1-2 SEQUENCE DIAGRAM, SYNCHRONISM	3
FIGURE 1-3 MEASURING CONCEPT, BLOCK DIAGRAM	4
FIGURE 2-1 BRACKETS WITH DIMENSIONS OF MOUNTING HOLES (20x20 BRACKET IN PARENTHESIS)	5
FIGURE 2-2 ELECTRICAL CONNECTIONS	6
FIGURE 3-1 ADJUSTING SIGHT	7
FIGURE 3-2 ADJUSTABLE HOLDER FOR DETECTOR.....	7
FIGURE 5-1 CONNECTION OF HAND TERMINAL WITH CABLE AND PLUG	11

1. PRODUCT DESCRIPTION

1.1 INTRODUCTION

The GD10L is an open path gas detector consisting of a combined transmitter/receiver unit and a separate reflector.

The GD10L is based on the highly acclaimed GD100 and GD10P point detectors. Over the past 15 years, the GD100 and GD10P have proven themselves to be the most reliable point detectors on the market. Like Simrad's range of point detectors, the GD10L has the advantage of using a solid-state, silicon-based IR source that requires no recalibration or replacement during its service life. The IR sources have an expected service life of more than 60 years, which keeps maintenance costs to a minimum. The IR sources are resistant to vibration and shock. And, unlike most detectors in use today, the GD10L will not cause any false gas alarms.

1.2 GENERAL DESCRIPTION

The GD10L fully implements the dual wavelength, dual optical path measuring concept. Radiation from the two silicon-based IR sources, which is chopped with a frequency of more than 50 Hz, passes through two narrowband optical filters. One wavelength is adapted to the gas to be detected while the other wavelength is chosen outside the absorption spectrum of the gas

The GD10L uses two IR detectors. Each detector receives radiation signals from both IR sources. Integrated in one unit, the transmitter and receiver are synchronised by the same microprocessor, which means that the synchronous operation of the unit can not be disturbed by IR beam interference.

The GD10L is by far the most advanced product on the market, and the only product that has built-in safety against false gas alarms caused by external interference or variations in optical and electronic components.

The GD10L continuously monitors the measuring path and the optical and electronic functions. The detector will always show correct gas concentration as long as there are no error messages.

The detector and reflector optics are heated to keep the optical surfaces free from dew, snow and ice. The heating element in the reflector is self-adjusting. Both the detector and reflector have solid weather protectors.

The GD10L can easily be installed by one person as only one unit requires accurate alignment. The detector and reflector brackets have been designed to resist vibration and shock. The reflector should be mounted perpendicular to the measuring path direction. Choice of reflector size is dependent on the length of the measuring path. Maintenance will normally consist in cleaning the detector and reflector optics. The detector gives an error message if cleaning is required.

1.3 AREAS OF APPLICATION

Area monitoring of:

- OIL AND GAS INSTALLATIONS ONSHORE AND OFFSHORE

Petrochemical plants

Chemical plants

Refineries

Pipelines

Marine

Waste disposal plants

Car parking buildings

Industry

THE GD10L OPEN PATH DETECTOR IS NORMALLY RECOMMENDED AS A SUPPLEMENT TO THE GD10P POINT DETECTOR, OR TO BE USED IN APPLICATIONS WHERE POINT GAS DETECTORS ARE UNSUITABLE.

1.4 PRINCIPLE OF MEASUREMENT

The GD10L uses two optical measuring paths, one external path, which measures gas concentration, and one internal path that monitor the optical and electronic components. By employing this concept, each detector measures both wavelengths. This concept prevents any possible drift caused by alterations in the IR sources, detectors and electronics from provoking false gas alarms.

The transmitter and receiver are integrated in one unit with direct synchronisation between transmitter and receiver functions so that false gas alarms caused by synchronisation errors are avoided. This measurement concept in combination with Simrad's unique IR sources result in a stable and reliable detector without false gas alarms or suppression of real gas alarms. Through Simrad's point detectors, this concept has shown a far better stability and reliability than any other detector concept on the market.

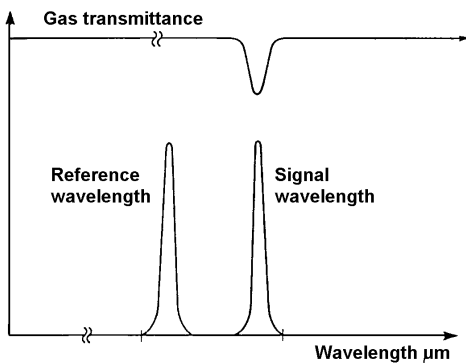

Figure 1-1 Transmission as a function of wavelength

One wavelength, the measuring wavelength, is chosen where the actual gas has a specific absorption line. The other wavelength, the compensation wavelength, is chosen where the gas has no absorption lines and where other gases and atmospheric conditions have no impact on the gas measurement. By comparing the amplitude of both wavelengths, before and after the IR beam has passed through the measuring path, the gas concentration is determined. Since both wavelengths are monitored by both IR detector elements, alterations in optical or electronic components are unable to cause erroneous measurements.

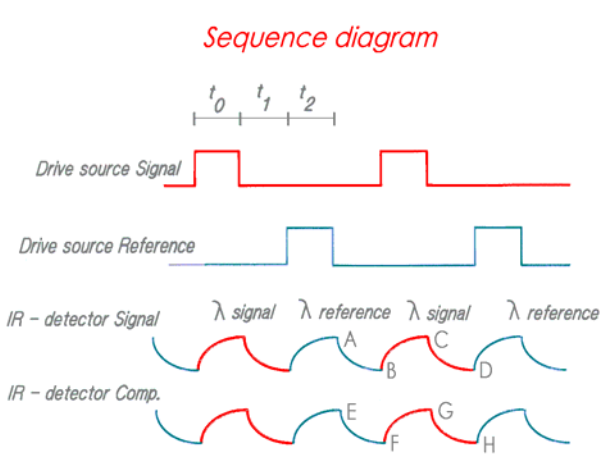

Figure 1-2 Sequence diagram, synchronism

There is no risk of unreliable measurements caused by synchronisation errors in the receiver unit since both the pulsing of the IR source and the timing of the IR detectors are directly controlled by the same microprocessor.

As in the point detector GD10P, the IR sources are silicon-based components with an expected service life of more than 60 years. They will not be impaired or damaged by mechanical shock or vibration.

The measuring concept has been used with great success in all types of operating conditions for more

than 15 years in the point detectors GD100 and GD10P.

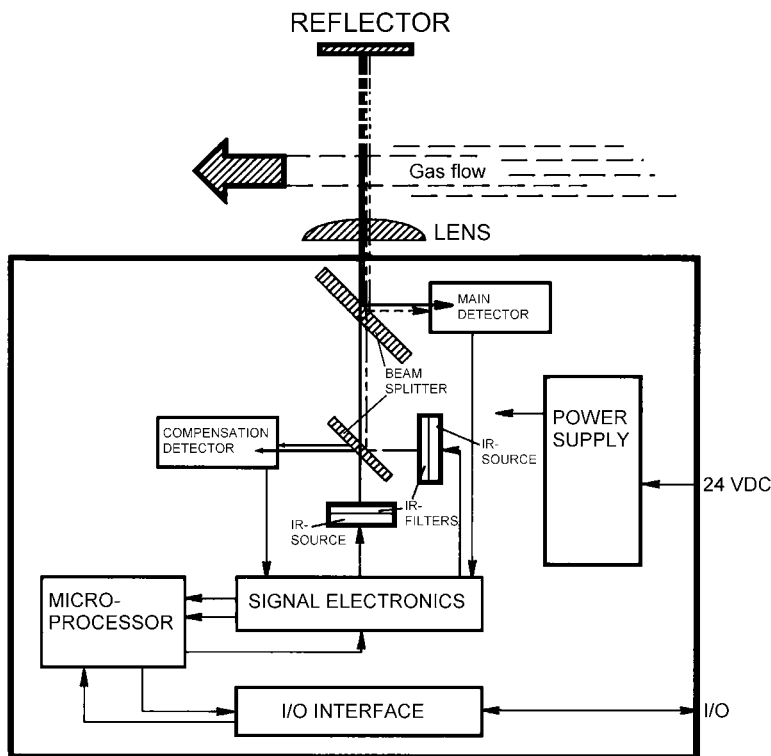

Figure 1-3 Measuring concept, block diagram

2. INSTALLATION

2.1 POSITIONING OF OPEN-PATH DETECTORS

The gas concentration of a gas cloud is reduced very rapidly as the distance from the source of the leak increases. The detector should therefore be placed as close as possible to potential leakage sources. Normally occurring wind directions must be taken into account when positioning the detector.

The detector should be placed between potential leakage sources and potential ignition sources.

In closed-in or protected areas the positioning of a detector should be determined by whether the gas is heavier or lighter than air.

2.2 MOUNTING OF THE DETECTOR AND REFLECTOR

The reflector bracket (ref. fig. 2-1) is to be fitted perpendicular to the measuring path, within ± 5 degrees. Both tilt and pan orientation of the panel should be within ± 5 degrees.

Because of their long and open measuring path, open-path detectors have relatively unprotected optics which are much more exposed to external interference than point detectors. To achieve maximum operating time, the local environment and the stability of the structure to which they are attached must be taken into consideration.

2.2.1 The following points should be taken into account when positioning open-path detectors

The measuring path should be horizontal. This reduces interference from rain, snow and sunlight. The detector should be attached to a mechanically stable structure to keep the device stable when subjected to the prevailing weather conditions and other mechanical loads such as, for example:

thermal movement due to the effects of the sun and temperature changes
the effects of strong wind
vibration from equipment such as pumps, turbines and cranes, high-pressure flushing of the detector etc.

The detector can be brought out of alignment by being knocked or as a result of some other mechanical effects, particularly if the detector is located in high-traffic areas.

UNDER THE ABOVE CONDITIONS, THE FOLLOWING REMEDIAL ACTIONS ARE RECOMMENDED:

The reflector should be attached to the structure which has the heaviest exposure to mechanical interference.

Use the large reflector (30x30)

Do not use long measuring paths.

The detector should be positioned in such a way that the measuring path does not cross the high-traffic areas and movable machinery cannot block the measuring path. Other factors to be taken into account could be temporary scaffolding, large vehicles etc.

The detector should be positioned in such a way that exhaust or steam discharges do not directly hit the optics.

In places where there can be thick fog or heavy snowdrifts the measuring path should be made as short as possible.

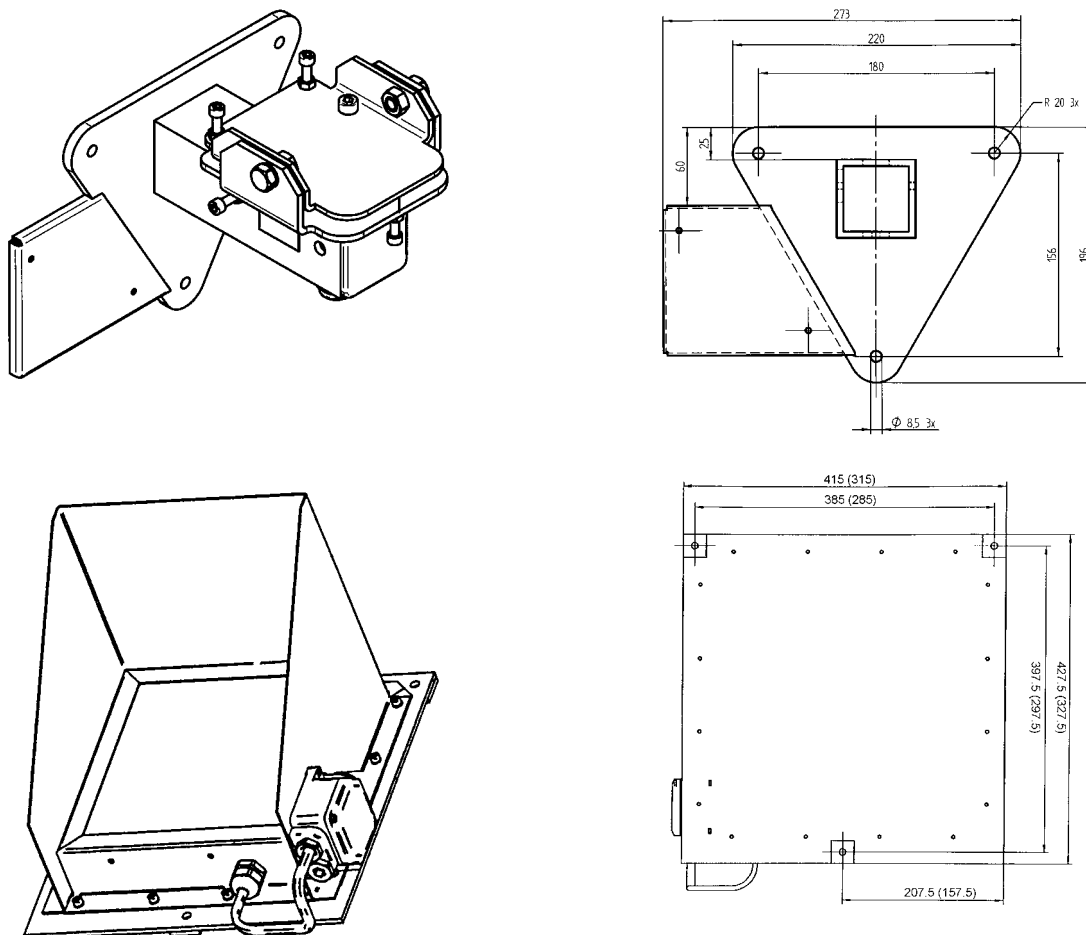
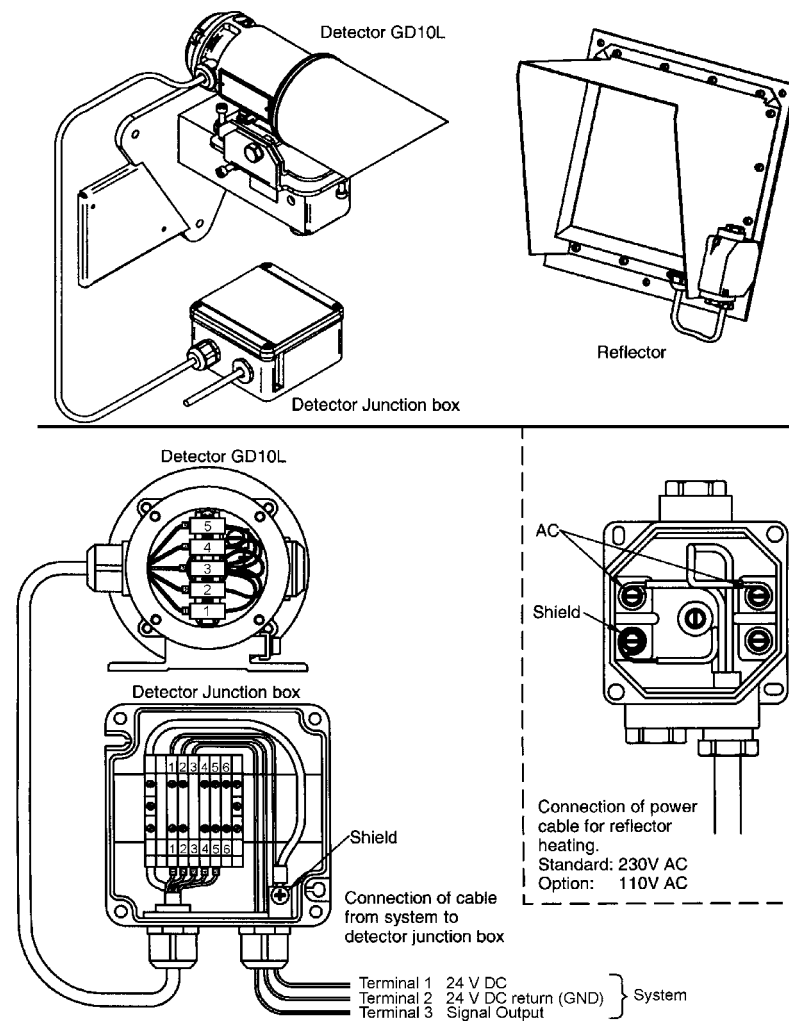

Figure 2-1 Brackets with dimensions of mounting holes (20x20 bracket in parenthesis)

2.3 ELECTRICAL CONNECTIONS



Detector, termination dep.	Junction box	System
1 +24 V	1 +24 V	+24 V
2 24 V return	2 24 V return	24 V return
3 4-20 mA output	3 4-20 mA output	4-20 mA input
4 +RS 485	4 +RS485	Not used
5 -RS 485	5 -RS 485	Not used
	6 Not used	Not used
- Shield	0 Shield	Shield

Electrical connections for reflector junction box:

Junction box	
1	220/110 V AC
2	220/110 V AC
3	Shield
4	Not used

Figure 2-2 Electrical connections

3. COMMISSIONING

3.1 PREPARATION

Check that the reflector is mounted perpendicular to the measuring path direction, within ± 5 degrees. Both tilt and pan orientation of the panel must be within ± 5 degrees. Commissioning should be carried out in clear weather in order to be able to calculate the transmission of the measuring path correctly, and to achieve the best possible accuracy of the zero-point calculation. Check that there is a free line of sight between the detector and the reflector. Check that optical surfaces on the detector and reflector are clean and dry. Check that there are no HC gases present during commissioning. Carry out rough setting using the adjusting sight.

3.2 COARSE ALIGNMENT USING THE ADJUSTMENT SIGHT

Fit the adjusting sight to the detector's weather protector using the rubber belt provided.



Figure 3-1 Adjusting sight

For simplest adjustment it is advantageous for the sight to be placed right on top of the weather protector, or in the middle of the side of the detector. The sight is used in the same way as pistol sights. There should be a distance of about 50 cm between the eye and the sight. Correct alignment of the sensor is obtained when both alignment rings and the centre of the reflector panel are aligned.

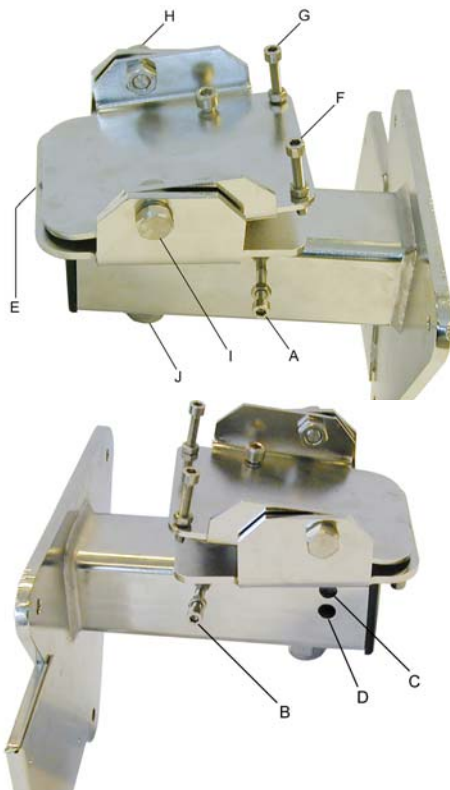

Figure 3-2 Adjustable holder for detector

3.2.1 Procedure

Note:
Screws H, I and J are not to be moved. These have already been adjusted at the factory.

Set adjusting screw A in the centre of the adjusting range and check that locking screw B is not restricting the adjusting range.
Check that locking screws C and D have been loosened so that the detector can be moved freely in the horizontal plane.
Align the detector in the horizontal plane.

Adjust the detector in the vertical plane using adjusting screw E. Check that locking screws F and G are not restricting movement.
 Tighten locking screws C and D with a torque of about 5 Nm.
 Re-adjust the detector using adjusting screws A and E so that the reflector is in the centre of the line of sight of the adjusting sight.

3.3 FINE-TUNING AND ZERO ADJUSTMENT USING THE HAND TERMINAL

The sight can now be removed from the detector.

Note:
The detector's measuring path must not be blocked during this part of the procedure.

3.3.1 Procedure

Connect the hand terminal to the terminal block in the junction box.
 The display will show the following text:

S	I	M	R	A	D		O	P	T	R	O	N	I	C	S				
T	e	r	m	i	n	a	l		f	o	r		G	D	1	0	L		
V	e	r	s		x	x													
M	E	N	U																↵

Press ENTER, ↵, on the terminal.
 The terminal displays the following text:

C	o	m	m	u	n	i	c	a	t	i	o	n		t	e	s	t		
P	l	e	a	s	e		w	a	i	t									
A	d	d	r	e	s	s		n	o		x	x							

When the terminal has identified the detector, the following text is displayed:

									↑										
S	e	n	s	o	r		i	n	s	t	a	l	l	a	t	i	o	n	
									↓										
S	E	L	E	C	T		F	U	N	C	T	I	O	N					↵

Select "Detector installation" by pressing ENTER. If necessary, use the arrow keys to find this function. The following text is displayed:

A	d	j	u	s	t		a	l	i	g	n	m	e	n	t		t	o	
m	a	x	.	s	i	g	n	a	l		a	n	d						
g	r	a	p	h		l	e	v	e	l									
L	o	c	k		a	d	j		s	c	r	e	w	s					↵

Press ENTER on the terminal. The following text is displayed:

S	i	g	n	a	l		l	e	v	e	l		x	x					
-	-	-	-	-	-	-	-	-	-	-	-	-	-	-					

After zero calibration is completed, the following text is displayed:

S	e	n	s	o	r		i	n	s	t	a	l	l	a	t	i	o	n
c	o	m	p	l	e	t	e	d										
D	I	S	P	L	A	Y		G	A	S		V	A	L	U	E		↵

After zero adjustment is completed, the detector automatically goes over to normal gas measuring mode.

Press ENTER to see the gas value as well as transmission along the measuring path. The following text is displayed:

P	a	t	h		t	r	a	n	s	m	.	X	X	X		%		
G	a	s		v	a	l	u	e				X	X		%		F	S
M	E	N	U															↵

Verify successful installation by checking that path transmission is approx. 100 % and that gas value is 0 % FS.

3.4 FUNCTION TEST

System and detector function test can be carried out using the Simrad Gas Test Filter. Proceed as follows:

- Hold the Gas Test Filter in the measuring path between the detector and the reflector for a minimum of 10 seconds. Preferably, hold the filter in front of the detector lens so that the plastic aperture covers the whole IR beam diameter. Read gas value at the terminal by choosing Display Gas Value in the menu. Refer to para. 5.4.2. Verify that reading approximately matches value printed on the rim of the Simrad Gas Test Filter. Or alternatively, read the gas value on the main control system.

4. MAINTENANCE

4.1 REGULAR MAINTENANCE

The detector does not have any internal functions that require regular monitoring or maintenance. If there is dirt on the detector lens or reflector window, they can be cleaned with mild soapy water or a mixture of isopropanol and water. Use a soft cloth. Before cleaning, the detector should be disconnected from the alarm system.

4.2 TROUBLESHOOTING

The detector can give fault messages in the event of weather conditions which to a considerable extent reduce or interfere with the transmission along the detector's measuring path or optics, or when objects block the detector's measuring path.

The detector can also give fault messages if the mounting brackets are not sufficiently stable over time or in the event of mechanical changes which may, for example, be caused by temperature changes or movement in the mounting structure. The above-mentioned conditions should be checked before troubleshooting is commenced.

Troubleshooting should always start by inspecting the detector's lens and reflector surface for contamination and defects. The following list may be helpful if problems arise:

Fault message	Problem	Correction
CLEAN OPTICS	Dirt on lens/reflector.	Clean optics. If necessary, re-adjust detector using terminal.
	Detector out of alignment.	Realign detector using terminal.
Blocked optics/detector failure	Dirt on lens/reflector.	Clean optics. If necessary, re-adjust detector using terminal.
	Detector out of alignment.	Straighten detector using terminal.
	Objects that block the measuring path.	Remove objects that block.

As a general rule if problems arise, inspect and clean both detector and reflector optics. If this does not help, realign the detector according to procedure (ref. Chapter 3).

5. TERMINAL

5.1 INTRODUCTION

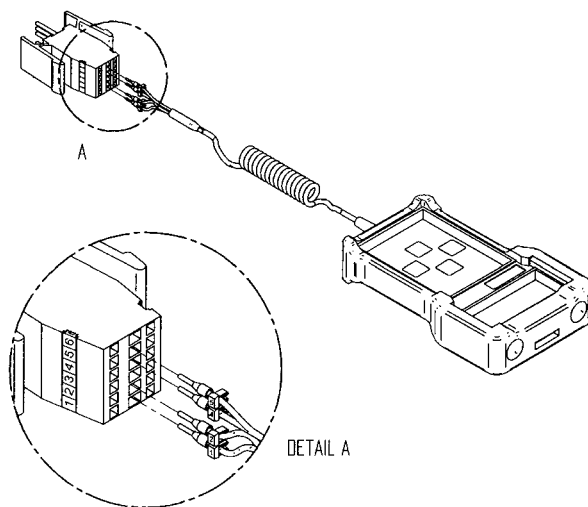

Figure 5-1 Connection of hand terminal with cable and plug

The terminal is used when setting, zero-adjusting and testing the detector.

The terminal communicates via a two-way RS 485 communication.

The terminal does not have any batteries that need to be changed, and the terminal is powered from the detector when it is connected.

5.2 DESCRIPTION OF TERMINAL

The terminal has a 4-line, 20-character backlit display, as well as 4 keys for navigating in menus and for operator output.

The terminal is connected to the detector via a plug, which fits into the terminal block in the detector's junction box.

THE KEYS UP AND DOWN SCROLL THROUGH MENUS

The key ENTER Acceptance of a particular function or menu selection

The key ESCAPE Discontinuation of menu selection in progress

5.3 START-UP

When the voltage is connected, the following start-up display appears:

S	I	M	R	A	D	C	P	T	R	C	N	I	C	S			
T	e	r	m	i	n	a	l	f	o	r	G	D	1	0	L		
V	e	r	s	x	x												
M	E	N	U													↵	

The menu is shown when ENTER is pressed.

The UP/DOWN keys are used to navigate in the menu.

Before the menu is displayed, the terminal checks the communication with the detector, with the following text being shown:

C	o	m	m	u	n	i	c	a	t	i	o	n	t	e	s	t		
P	l	e	a	s	e	w	a	i	t									
A	D	D	R	E	S	S	N	C	X	X							↵	

If however the terminal is not able to establish communication with the detector, the following text is displayed:

C	o	m	m	u	n	i	c	a	t	i	o	n	f	a	u	l	t		
R	E	S	T	A	R	T												↵	

When ENTER is pressed, the terminal makes a new attempt to establish communication with the detector.

The following functions can be selected from the menu list:

- Detector installation
- Display gas value
- Fault messages

5.4 FUNCTIONS

5.4.1 Installation of detector

This function is described in chapter 3.3: Fine-tuning and zero adjustment by terminal.

5.4.2 Display gas value

This function continuously reads the detector's gas value as well as optical transmission along the measuring path. The following text is displayed:

P	a	t	h	t	r	a	n	s	m	.	X	X	X	%				
G	a	s	v	a	l	u	e				X	X	%					
M	E	N	U															↵

where "Path transm." is the transmission in % along the detector's measuring path.
 "Gas value" is the gas reading as a % of the full scale value.

6.2 ADJUSTABLE BRACKET FOR DETECTOR

Material	316, acid-proof stainless steel
Weight	5.5 kg
Dimensions	200 x 220 x 220 mm

6.3 REFLECTOR 20x20 CM

Mounting	The reflector is to be mounted perpendicular to the measuring path direction within ± 5 degrees.
Recommended path length	2–20 metres
Power supply	220 V AC (option 110 V AC)
Power consumption	Max. 60 W at power-up/15 W normal operation
Ex classification	Ex e (when using heater cable)
Material	316, acid-proof stainless steel
Weight	8.5 kg
Dimensions	262.5 x 315 x 327.5 mm

6.4 REFLECTOR 30x30 CM

Mounting	The reflector is to be mounted perpendicularly to the measuring path direction within ± 5 degrees.
Recommended path length	2–30 metres
Power supply	220 V AC (option 110 V AC)
Power consumption	Max. 60 W at power-up/15 W normal operation
Ex classification	Ex e (when using heater cable)
Material	316, acid-proof stainless steel
Weight	14 kg
Dimensions	308 x 415 x 427.5 mm

6.5 TECHNICAL DATA, ACCESSORIES

6.5.1 Gas filter

Dimension of external diameter	16.5 cm
Dimension of aperture	12 cm
Gas response	Approx. 2.4 LELm on standard detector

6.5.2 Adjusting sight

Dimensions	15 x 6 x 3.5 cm
Weight	180 g
Material	anodised aluminium

6.5.3 Hand terminal

Dimensions	10 x 18 x 4 cm
Weight	450 g
Power supply	24 V nominal, range 18–32 V
Current consumption	0.7 W
Communication	RS485
Ex class	None. Internal voltages only when connected to junction box

6.6 CERTIFICATIONS

GD10L is certified in accordance with the requirements that are stated in "Electrical apparatus for explosive atmospheres" formulated in the following standards from CENELEC:

EN 50014 (1997) Electrical apparatus for potentially explosive atmospheres. General requirements
Amendment A1 (1999)
Amendment A2 (1999)

EN 50018 (1994) Electrical apparatus for potentially explosive atmospheres. Flame-proof enclosure "d"

EN 50019 (1994) Electrical apparatus for potentially explosive atmospheres. Increased safety "e"

EN 50081-1 (1992) Electromagnetic compatibility - Generic emission standard. Part 1: Residential, commercial and light industry

EN 50082-2 (1997) Electromagnetic compatibility - Generic immunity standard. Part 2: Industrial environment

IEC 529 Classification of degrees of protection, First Edition 1996
Amendment no. 1 (1978)

6.7 CERTIFICATES

Certificate of Conformity: NEMKO No. 00 ATEX138 X
in accordance with ATEX Directive 94/9/EC

7. ORDERING INFORMATION

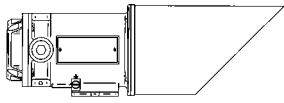
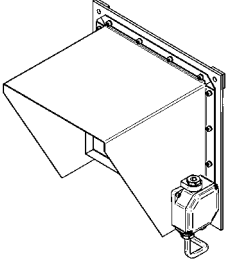
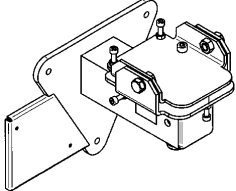
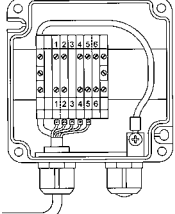
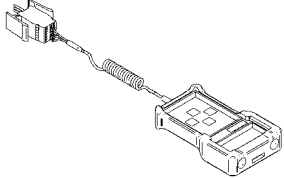
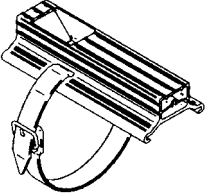
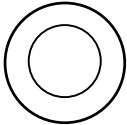
	Description	Order no.
	Gas Detector GD10L source Gas Detector GD10L sink	128-811960.4 128-813232.6
	Reflector 20x20 Assy 220 V AC REFLECTOR 20X20 ASSY 110 V AC Reflector 30x30 Assy 220 V AC Reflector 30x30 Assy 110 V AC	499-812837.3 499-813540.2 499-813022.1 499-813541.0
	Mounting Bracket Assy	499-812468.7
	Junction Box Assy	108-904807.6
	Hand Held Terminal Assy	109-813103.9
	Tool Alignment Assy	708-812800.1
	Filter Gas Test Assy No 1 Filter Gas Test Assy No 2	419-813183.1 419-813663.2

