

PARAT MEW

Exhaust Gas Water Tube Boiler



PARAT MEW: Exhaust Gas Water Tube Boiler

Technical data

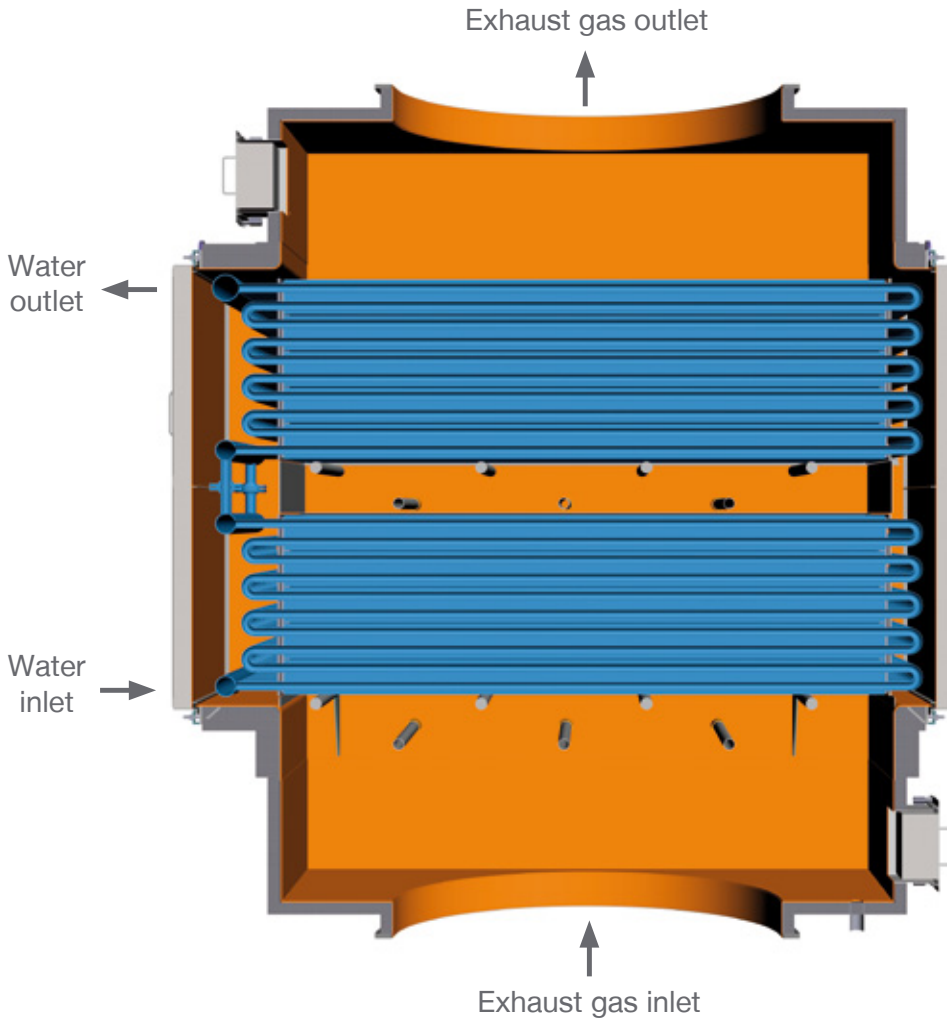

- Water tube type
- Compact
- High Performance
- Approved by DNV, LRS, BV, ABS, etc.

The water tube boiler consists of finned tube or bare tube bundles mounted together in sections.

The water circulates through the tubes and the extended heating surface on the exhaust gas side makes this boiler compact.

The water flow is generated by circulation pumps and evaporation takes place in the boiler. The water/steam mixture is then separated in a steam drum or in an auxiliary boiler.

The boiler can be controlled by a surplus valve and a condenser, or by a three-way exhaust gas damper. The boilers are pre-assembled and delivered as a complete unit.

Needs proper water treatment and cleaning.



NS-EN ISO 9001
CERTIFIED COMPANY

