



## 1000 Standard



**En sikker investering for et krevende arbeidsmiljø**  
*A safe investment for a demanding work environment*

# Nor-Sap 1000 Standard

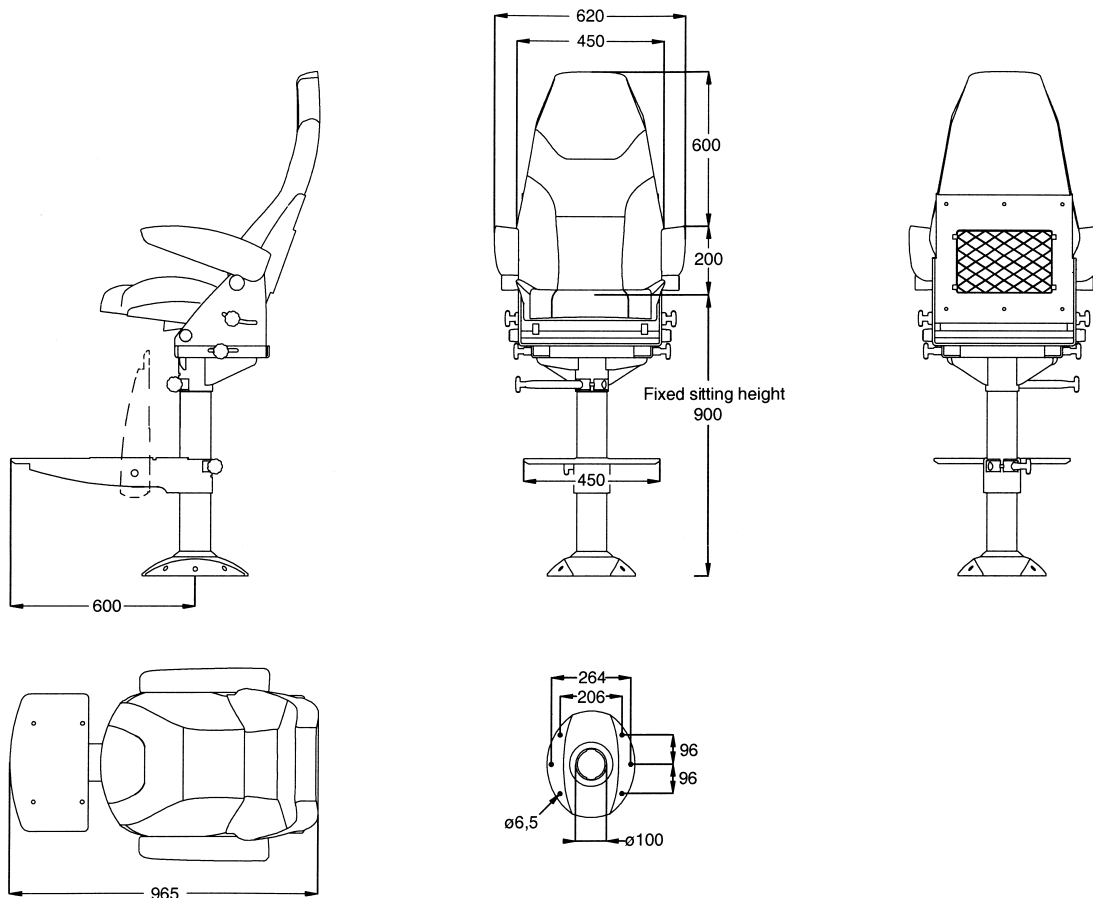

## Nor-Sap 1000 Standard

føyer seg inn i rekken av våre velkjente skipsførerstoler. Setet har en riktig ergonomisk utførelse og har en god sidestøtte. Setet er festet til en  $\varnothing 100$  mm søyle. Nor-Sap 1000 er produsert i aluminium. Sete, rygg og armhviler er trukket i hud, velur eller stoff i fargene sort, rød, blå, grå eller grønn. Andre stoffer og farger på forespørsel. Oppgi stoff og farge ved bestilling.

(Leveres i sort hud hvis ikke annet er spesifisert i ordren.)

## Funksjoner:

- Regulerbar sete og rygg
- Regulerbare armhviler som kan slåes opp
- Sete skyves fram og tilbake
- Dreibar 360°
- Fothviler kan vippes opp.

**Vekt:** 38 kg  
**Nor-Sap 1000 Standard:** Art.nr: 6000

(Oppgi type trekk og farge ved bestilling)

**Varetrekk:** **Stoff:** Art.nr: 6050  
**Vannavvisende:** Art.nr: 6041  
**Dørkskinne:** Se egen brosjyre

## Nor-Sap 1000 Standard

fits right into our well-known line of popular helmsman seats. This seat is designed to high standards of ergonomics and provides a stable lateral support. This seat is mounted on  $\varnothing 100$  mm column. The Nor-Sap 1000 is made of aluminium. Seat, back and arm rest are upholstered in leather, velour or fabric in the colors of black, red, blue, grey and green. Other colors or fabrics available upon request. State colors or fabrics when ordering.

(Chairs will be delivered in black leather, if no other preference is stated on the order.)

## Functions:

- Adjustable seat and back
- Adjustable flip-up arm rests
- Seat moves forward and back
- 360° swivel
- Foot rest folds up.

**Weight:** 38 kg  
**Nor-Sap 1000 Standard:** Art. No: 6000

(State upholstery and color on order)

**Seat cover:** **Fabric:** Art. No: 6050  
**Water repellent:** Art. No: 6041  
**Deck Rail:** See brochure

## AS Sørlandets Aluminiumprodukter

Boks 7005, Vestheiene Telefon: (47) 38 18 52 00  
N-4674 Kristiansand Telefaks: (47) 38 18 20 86  
Norway E-mail: sale@norsap.no  
Internett: www.norsap.no



Forhandler / Dealer: